

MORTUARY LIFT COMPANY™

A L i f t i n g E x p e r i e n c e ™

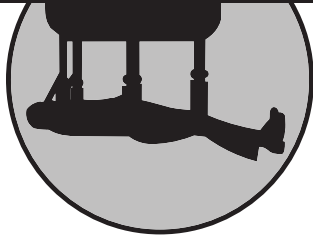

THE ULTIMATE 1000 LIFT™

800-628-8809

319-364-4910

www.mortuarylift.com

Installation Manual

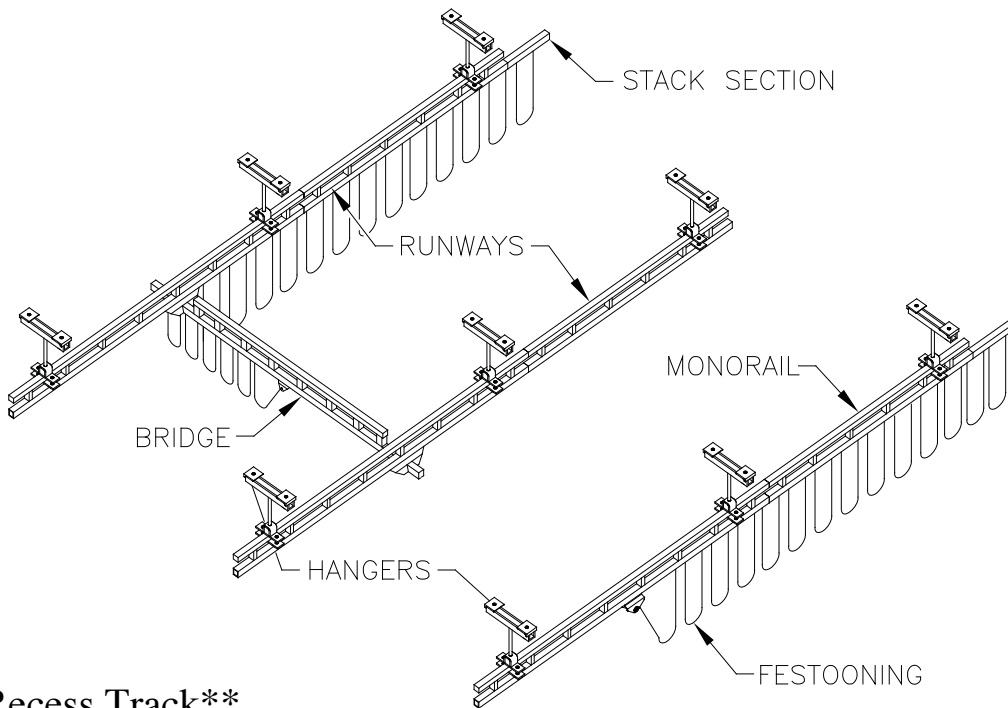

****Do Not Recess Track****

Lift will scratch ceiling under
load if recessed

**IMPORTANT!
DO NOT DESTROY**

Ceiling Mounted Steel Work Station and Monorail

Mortuary Lift Company® Order No. _____

Serial Number: _____

Company _____

Name: _____

Date _____

Month

Year

TABLE OF CONTENTS

Introduction	1
Installation	
Step 1 - Pre-assembly	1
Step 2 - Hanger Installation	2-3
Step 3 - Runway Installation.....	5
Step 4 - Splice Joint Installation	7
Step 5 - Bridge and End Truck Installation.....	8,9,12
Step 6 - Hoist Trolley Installation.....	12-13
Step 7 - Festoon Stack Section Installation.....	15
Step 8 - Festooning Installation	16-17
Applied Forces to the Supporting Structure	28
Sway Bracing and Thrust Bracing Guidelines	29
Crane Operator Instructions	30
General Operational Suggestions	30
Limited Warranty.....	31
Inspection and Maintenance Schedule.....	32

Questions? Concerns? Comments? Please call (800) 628-8000

INTRODUCTION

Thank you for choosing Mortuary Lift Ceiling Mounted Work Station to solve your material handling needs. The innovative design and heavy-duty construction of the Work Station will provide a superior quality product that will offer years of long term value. All workstations are pre-engineered for powered hoist operation. The hoist weight allowance is 15% of the work station capacity (for example, a work station rated for 1000 pounds, allows for a 1000-pound live load plus 150 pounds for the weight of the hoist). There is also an allowance of 25% of the work station capacity for impact caused by hoist use. Mortuary Lift Work Stations will provide many years of dependable service by following the installation and maintenance procedures described herein.

Dimensions contained in this installation manual are for reference only and may differ for your particular application. Please refer to the enclosed General Arrangement Drawing for actual dimensions.

Normal safety precautions: These include, but are not limited to:

- Checking for obstructions in hoist travel
- Checking that all bolts and threaded rods are tight and have lockwashers
- Making sure that end stops are in place
- Making sure that festooning cannot be snagged or pinched, whether it is electric or pneumatic

For additional safety precautions, see page 30.

WARNING

Equipment described herein is not designed for, and should not be used for, lifting, supporting or transporting live humans. Failure to comply with any one of the limitations noted herein can result in serious bodily injury and/or property damage. Check State and Local regulations for any additional requirements.

WARNING

Crane cannot be utilized as a ground: A separate ground wire is required. For example, systems with 3-phase power require three conductors plus one ground wire.

WARNING

Before installing any crane system, it is critical you determine that your building will safely support the loads. Mortuary Lift, Inc. assumes no responsibility for adequacy or integrity of the mounting surface.

WARNING

Sway bracing is required (except when using flush mounted hangers). For more information see page 29.

WARNING

Reference the American Institute of Steel Construction (AISC) Manual of Steel Construction (9th edition), Part 5, Specification for Structural Joints using ASTM A325 or A490 Bolts (section 8.d.2) for the proper procedures to follow when using any torque-tightening method.

INSTALLATION

STEP 1 - PRE-ASSEMBLY

➔ **TIP:** Packing list can be found in plastic pocket attached to the hardware box: General Arrangement Drawing and additional inserts can be found enclosed in this installation manual.

- 1.1 Read entire installation manual **before** you begin installing your work station.
- 1.2 Check packing list to make sure **correct quantity** of parts is included.
- 1.3 Tools and materials (by others) typically needed to assemble work station are as follows:
 - Hand tools
 - Leveling tools
 - Ladders/man lifts
 - Powered metal-cutting saw
 - Steel shims (for flush mounted hangers)
 - Torque wrench (able to torque up to 200-ft. lb.)

STEP 2 - HANGER INSTALLATION

- ➔ **NOTE:** Standard top hanger brackets are designed for flange widths from 1"-3", 3-1/4"-5-1/4", 5-1/2"-7-1/2", 8"-10".
- ➔ **NOTE:** For galvanized systems, hardware is not galvanized. You will need to use cold galvanizing spray provided on any unplated/galvanized hardware.

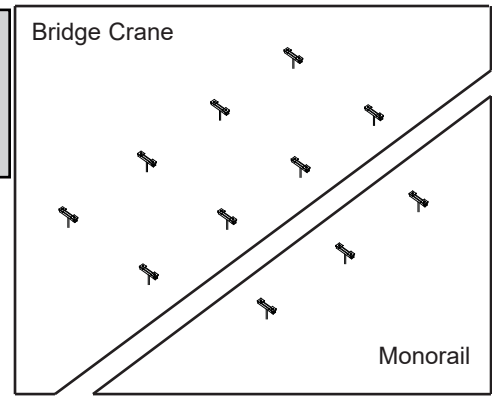

Top Hanger Assemblies

2.1 Mark top hanger placement on the building support beams and runway/monorail track (refer to the **General Arrangement Drawing**, inserted in this manual, for hanger placement). Installation parameters can be found on page 28.

If you have standard hangers, go to Step 2.2.

If you have sloped hangers, go to Step 2.3.

2.2 To attach threaded rod to top hanger bracket:

WARNING

Threaded rod must have a minimum of two threads beyond the hexnut.

Assemble top hanger assembly (*diagram 2A*). Refer to **Chart 2A** for proper nut torque.

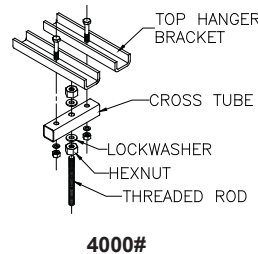
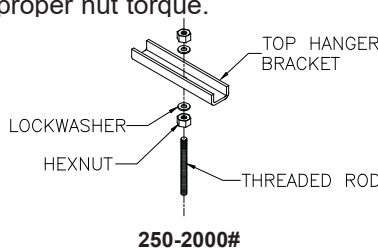

Diagram 2A. Attaching threaded rod to top hanger bracket.

TORQUE CHART	
*Bolt Diameter	Torque
1/2"	50 ft.-lb.
5/8"	95 ft.-lb.
3/4"	150 ft.-lb.

Chart 2A. Torque Chart.
*Note: All bolts shall be SAE Grade 5 or equal.

WARNING

Torque values in this chart reflect standard values. Some components require lower values and they are specified throughout this manual. Only use this chart when no value is called out.

Go to Step 2.4, on page 3.

2.3 To attach clevis to top hanger bracket:

WARNING

Sloped ceiling hangers must not be installed on beams more than 15 degrees from horizontal.

Assemble top hanger assembly (*diagram 2B*). Refer to **chart 2A** for proper nut torque. Insert threaded rod into clevis (*diagram 2D*).

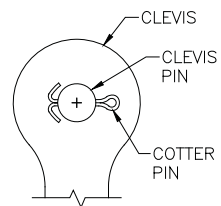
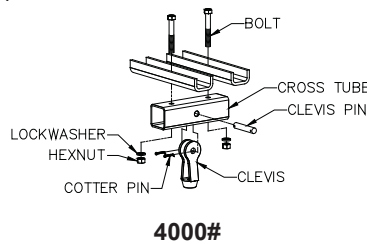
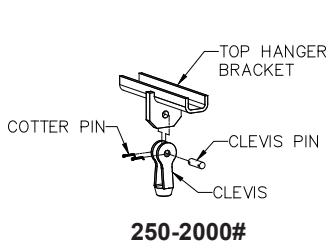

Diagram 2C. Installing cotter pin through clevis pin.

Diagram 2B. Attaching clevis to top hanger bracket.

Bend **both legs** of all cotter pins (*diagram 2C*).

WARNING

Fully bend both legs of cotter pin (*diagram 2C*). If cotter pin is cracked or fatigued it must be replaced.

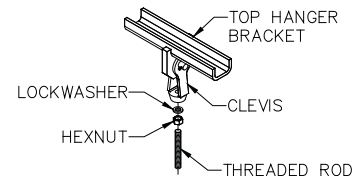

Diagram 2D. Attaching threaded rod to clevis.

WARNING

Threaded rod must have a minimum of two threads beyond the clevis.

STEP 2 - HANGER INSTALLATION (CONTINUED)

- 2.4 Bolt top hanger bracket assembly and beam clips to building support beam (**diagram 2E or 2F**).
Note: Flange thickness may vary and require shimming. Shimming may be needed to assure that the beam clip hardware is vertical.

WARNING

“Center hole” of the top hanger bracket assembly must be centered on building support beam.

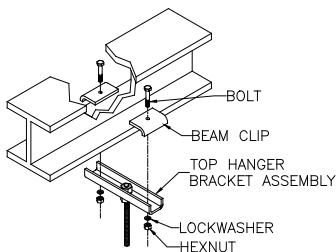

250-2000#

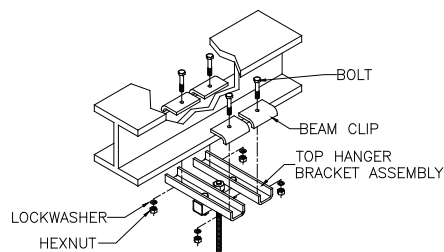

4000#

Diagram 2E. Bolting standard top hanger bracket and beam clips to existing support beam.

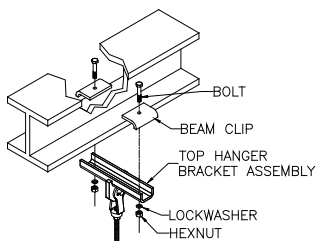

250-2000#

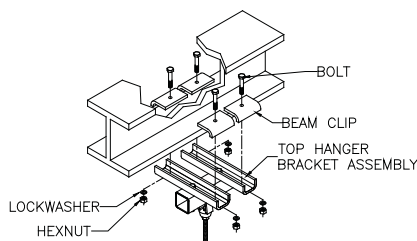

4000#

Diagram 2F. Bolting sloped top hanger bracket and beam clips to existing support beam.

Lower Hanger Assemblies

- 2.5 For untrussed (plain) track:

WARNING

Do not over-tighten clamping bolts on the lower hanger assemblies: this will cause permanent damage to the runway track.

Slide lower hanger assembly over the runway track and bolt into place with clamping bolts (**diagram 2G**).

Note: Install the vertical bolts for beam clips (Step 3.2, on page 5) on the Perpendicular Flush Mount Hanger 250-2000# (**diagram 2G**), **before** sliding it on the track.

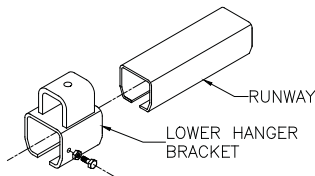

Plain Track 250-2000#

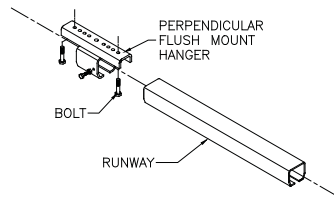

Perpendicular Flush Mount 250-2000#

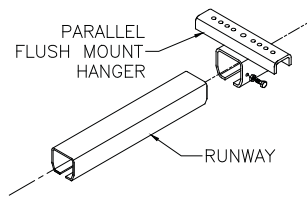

Parallel Flush Mount 250-2000#

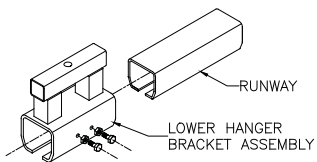

Plain Track 4000#

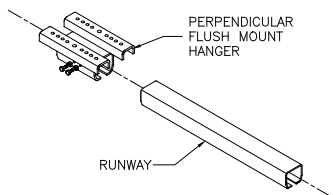

Perpendicular Flush Mount 4000#

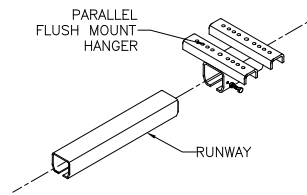

Parallel Flush Mount 4000#

Diagram 2G. Installing lower hanger assemblies on untrussed (plain) track.

STEP 3 - RUNWAY INSTALLATION

- ➔ **NOTE:** The closer the runways/monorails are to level and parallel, the better the Lift will perform.
- ➔ **NOTE:** Track running-surface misalignment at joints shall be adjusted to within 1/32" (1mm) when installed.
- ➔ **NOTE:** For galvanized systems, hardware is not galvanized. You will need to use cold galvanizing spray provided on any unplated/galvanized hardware.

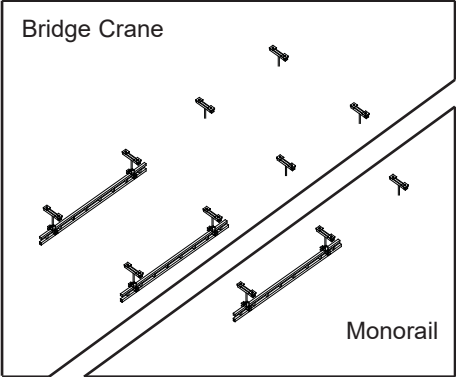

- 3.1 Lift the runway/monorail into place for installation.
- 3.2 Hangers

WARNING
Threaded rod must have a minimum of two threads beyond the hexnut.

WARNING
Threaded rod must be allowed to hang "plumb" and should not be bent to accommodate sloped ceilings.

For standard and sloped ceiling hangers with threaded rod drop:
Insert threaded rod into bolt hole on the lower hanger assembly and bolt into place (*diagram 3A*).

Torque nuts (*chart 2A*, page 2, for proper torque rating).

For flush mounted standard hangers:
Bolt flush mounted hanger and beam clips to building support beam (*diagram 3B*).

Torque nuts (*chart 2A*, page 2, for proper torque rating).

For flush mounted sloped ceiling hangers:
Insert bolt, with lockwasher, into bolt hole on the lower hanger assembly and fasten to clevis (*diagram 3C*).

Torque hardware (*chart 2A*, page 2, for proper torque rating).

WARNING
Bolt must have a minimum of two threads beyond the clevis.

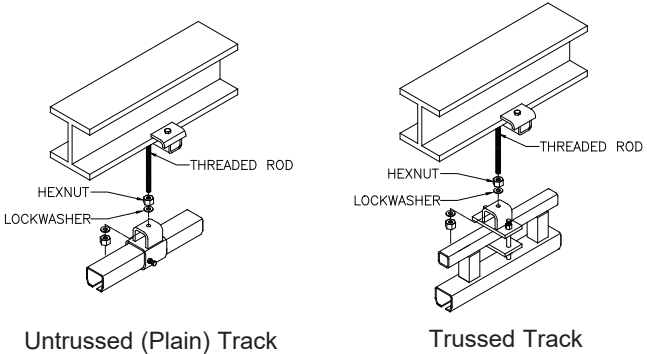

Diagram 3A. Attaching lower hanger assembly to top hanger assembly.

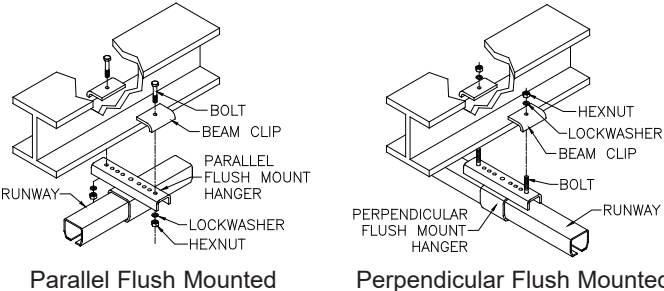

Diagram 3B. Attaching flush mounted hangers to building support beam.

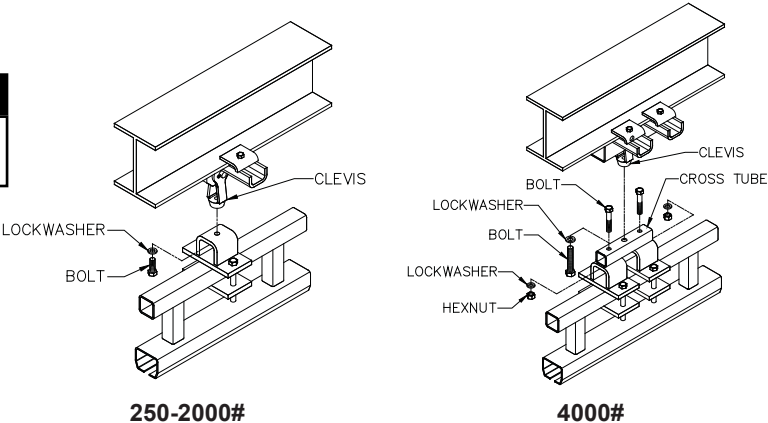

Diagram 3C. Attaching flush mounted sloped ceiling hangers to top hanger assembly.

***One end of track needs at least 15 inches of clearance to allow room for trolley removal.

STEP 4 - SPLICE JOINT INSTALLATION

- ➔ **IMPORTANT:** If using trussed track, use both the splice joint and the splice plate.
- ➔ **IMPORTANT:** Suitable splices shall be provided at all track joints.

WARNING

Do not deviate from the dimensions specified in the General Arrangement Drawing for maximum space from hanger point to splice joint. Installation parameters can be found on page 28.

- 4.1 Attach hardware to splice joint. Slide splice joint over track of installed runway/monorail.
- 4.2 The maximum gap between ends of the load carrying flange shall not exceed 1/16" (1.5mm).
- 4.3 Slide next runway/monorail section into splice joint, bringing runway/monorail ends as close as possible (*diagram 4A* or *4B*).
Center the splice joint over the track ends.
- 4.4 **For trussed track:** Place a truss splice plate on each side of runway truss tube and bolt into place (*diagram 4B*). Tighten hexnuts, but **do not torque** until you have completed Steps 4.4 and 4.5.
- 4.5 Refer to Step 2.5, on pages 3 and 4, for lower hanger installation. Attach runway to upper hanger by repeating Steps 3.2, on page 5 and 3.4, on page 6.
- 4.6 **Adjust track for smooth transition:**

WARNING

Do not "over-tighten" clamping bolts on splice joints: this will cause permanent damage to the runway track. Clamping bolts are utilized for alignment purposes.

Tighten clamping bolts along the **top of splice joint** to force track down onto lower flanges of splice. Check to see that the transition from one track to the other is smooth: no raised areas to inhibit trolley or end truck operation.

Tighten clamping bolts along the **sides of splice joint** to align track laterally. Check to see that track portion of runway/monorail is horizontally and vertically flush.

Tighten jam nuts, on both the top and sides of the splice joint, to lock clamping bolts in place (*diagram 4A* or *4B*).

- 4.7 **For trussed track:** After you have adjusted the track for smooth transition, torque the truss splice plate hexnuts (*chart 2A*, on page 2).
- 4.8 For additional runways repeat Steps 4.1 through 4.6.
- 4.9 Install end stops (Step 3.4, on page 6).

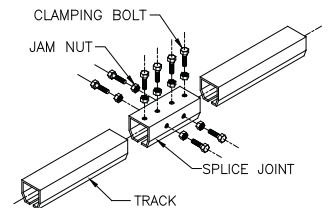
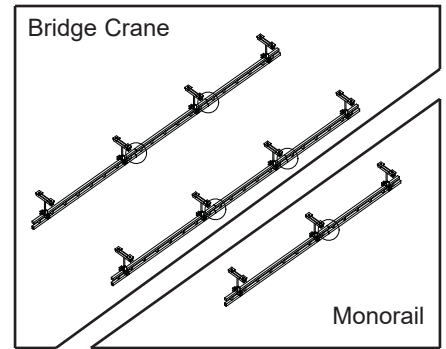

Diagram 4A. Splicing untrussed track.

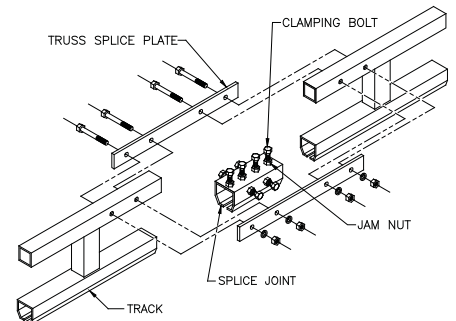
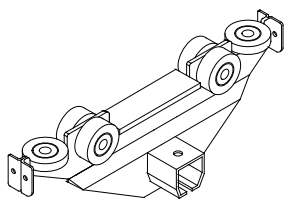
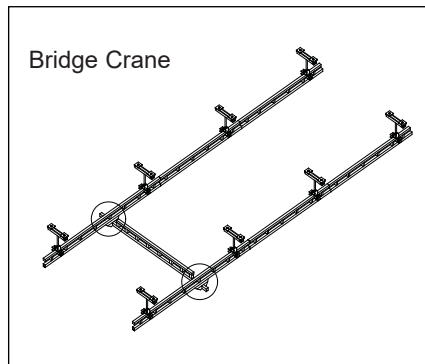

Diagram 4B. Splicing trussed track.

STEP 5 - BRIDGE AND END TRUCK INSTALLATION

➔ **IMPORTANT: ONLY ONE** end truck is clamped to the bridge: the other is not. The clamping end truck must be oriented with the festooning side of the track (refer to Step 8, on page 16 for festooning). The non-clamping end truck allows adjustment for any runway misalignment.

- 5.1 Make sure end stops have been installed in the runway end opposite the festooning (leaving festooning end open for bridge installation).
- 5.2 Prior to adding bridge, clean inside flanges of track with clean, dry cloth (**do not use any kind of cleaning solution**) to remove grit or debris that may have collected during shipping, storage, or installation.
- 5.3 If your end trucks look like:



(Shipped Assembled)
go to Step 5.4

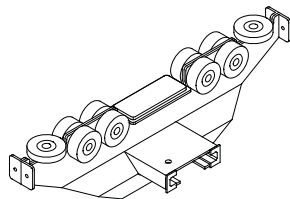

(Shipped Assembled)
go to Step 5.7

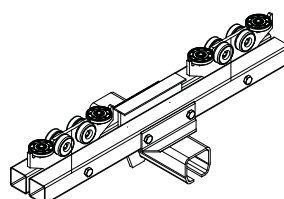

(Shipped Unassembled)
go to Step 5.19

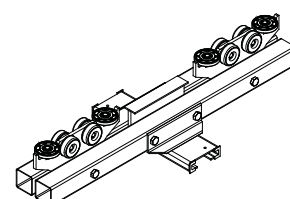

(Shipped Unassembled)
go to Step 5.29

Standard End Trucks

➔ For Steel Bridges

- 5.4 Slide an end truck over festooning end of bridge (refer to the **General Arrangement Drawing** for exact end truck location, end truck sleeve must be 1" (+/- 1/4") from first vertical) and clamp into place with hardware provided (**diagram 5A**).

Note: The festooning end of the bridge will have a hole that is inset the same or greater distance from the end of the bridge than the hole in the opposite end of the bridge.

- 5.5 Slide and position the non-clamping end truck on the other end of bridge (refer to the **General Arrangement Drawing** for exact location, end truck sleeve must be 1" (+/- 1/4") from first vertical).

- 5.6 Go to Step 5.40, on page 12.

➔ For Non-Coped Aluminum Bridges

- 5.7 Make sure nylon spacers are attached to end truck before installing end truck on bridge.

- 5.8 Slide an end truck over festooning end of bridge (refer to the **General Arrangement Drawing** for exact end truck location) and clamp into place (**diagram 5B**).

Note: The festooning end of the bridge will have a hole that is inset the same or greater distance from the end of the bridge than the hole in the opposite end of the bridge.

- 5.9 Slide and position the non-clamping end truck on the other end of bridge (refer to the **General Arrangement Drawing** for exact location).

- 5.10 Go to Step 5.14, on page 9.

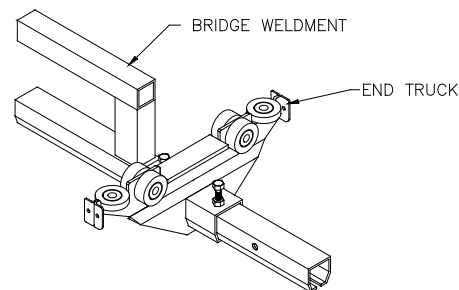

Diagram 5A. Installing standard clamping end truck. See **NOTE**.

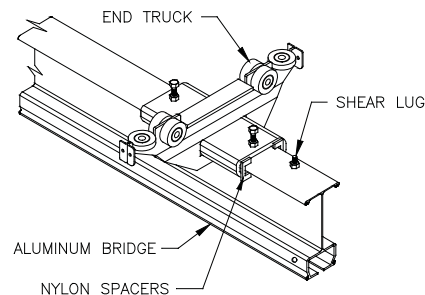

Diagram 5B. Installing clamping end truck on aluminum bridge. See **NOTE**.

STEP 5 - BRIDGE AND END TRUCK INSTALLATION (CONTINUED)

➔ **NOTE:** ONLY ONE end truck is clamped to the bridge; the other is not. The clamping end truck must be oriented with the festooning side of the track (refer to Step 8, on page 16 for festooning). The non-clamping end truck allows adjustment for any runway misalignment.

Standard End Trucks (continued)

➔ For Coped Aluminum Bridges

5.11 Make sure nylon spacers are attached to end truck before installing end truck on bridge.

5.12 Slide an end truck over coped brackets on the festooning end of bridge (refer to the **General Arrangement Drawing** for exact end truck location) and clamp into place (**diagram 5C**).

Note: The festooning end of the bridge will have an end stop hole that is inset the same or greater distance from the end of the bridge than the end stophole in the opposite end of the bridge.

5.13 Slide and position the non-clamping end truck on the other end of bridge (refer to the **General Arrangement Drawing** for exact location).

5.14 At both ends of bridge, install a shear lug bolt in hole at top of bridge (or in the coped brackets) to prevent bridge from sliding out of end trucks (**diagrams 5B**, on page 8, and **5C**, above).

Note: Install bolts with head of bolt on underside of top flange with threads pointing up.

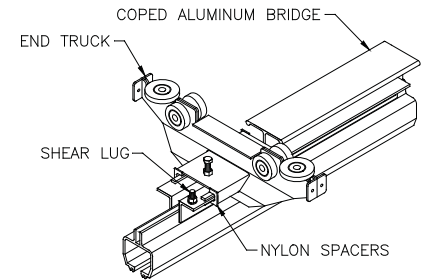

Diagram 5C. Installing clamping end truck on coped aluminum bridge. See **NOTE**.

WARNING

Failure to install shear lug bolt assemblies may result in the bridge, hoist, and load falling to the floor.

5.15 If a **tow arm is not** being utilized on the end truck, go to Step 5.40, on page 12.

If a **tow arm is** being utilized on the end truck, go to Step 5.16.

Note: Festoon tow arms are not recommended for use on 4000# systems or systems with extended end trucks. They are not necessary on systems with festoon trolleys.

5.16 Assemble the tow arm weldment on the end truck that will be located on the festooning side of the system (**diagram 5D**). Be sure that the tow arm is located on the festooning side of the end truck itself when installed.

5.17 Assemble the tow arm spacer on the end truck located at the opposite end of the bridge (**diagram 5E**). Be sure the spacer is mounted on the same side of the end truck as the tow arm weldment.

5.18 After the bridge has been installed, loosen the nuts on the end of the U-bolt enough to thread cable/air hose between the two legs of the U-bolt and the festoon clamp plate. Secure cable/air hose by tightening nuts at the end of the U-bolt, forcing the festoon clamp plate snug against the cable/air hose.

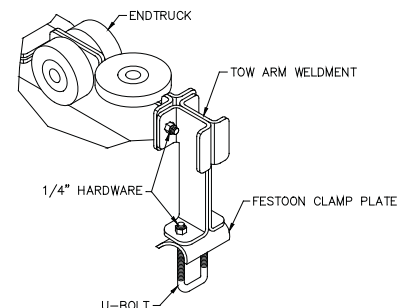

Diagram 5D. Installing tow arm on end truck.

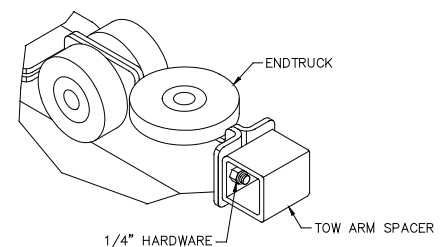

Diagram 5E. Installing tow arm spacer on end truck.

STEP 5 - BRIDGE AND END TRUCK INSTALLATION (CONTINUED)

➔ **NOTE:** ONLY ONE end truck is clamped to the bridge: the other is not. The clamping end truck must be oriented with the festooning side of the track (refer to Step 8, on page 16 for festooning). The non-clamping end truck allows adjustment for any runway misalignment.

Extended End Trucks (continued)

- 5.40 Install an end stop to the end of the bridge opposite the festooning (*diagrams 5L or 5M*).

WARNING

Do not over-tighten nylock nut; this could cause damage to bridge. Nylock nut can only be used once. If this item is disassembled, then nut must be replaced.

- 5.41 Lift bridge up to runways and simultaneously insert end trucks into open ends of runways. Make sure festooning end of bridge is oriented with festooning runway. For information on festooning, refer to Step 8, on page 16.
- 5.42 **Immediately** install end stops in open ends of runways to prevent bridge from exiting runways (*diagrams 5N or 5O*).
- 5.43 Roll bridge down length of runways to check for smooth travel. If travel is not smooth, check track for level and parallel (Step 3.4, page 6) and check to make sure that only one end truck on bridge is clamped.

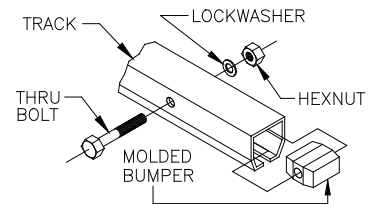

Diagram 5L. Installing end stop.

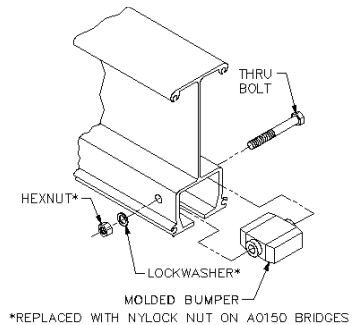
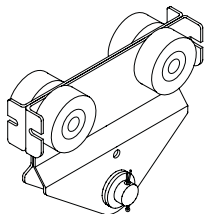

Diagram 5M. Installing end stop.

STEP 6 - HOIST TROLLEY INSTALLATION

- 6.1 If your hoist trolley looks like:



(shipped assembled)
go to Step 6.2

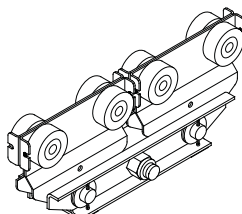

(shipped assembled)
go to Step 6.13

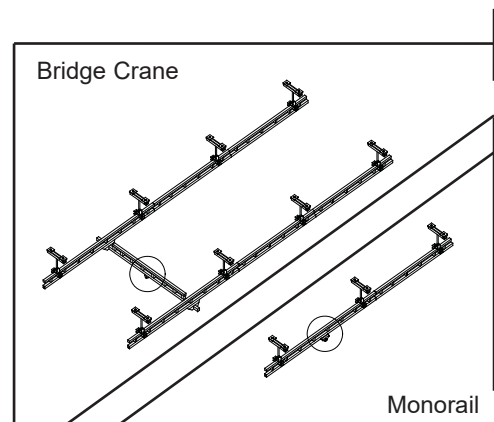

150#, 250#, 500#, 1000# and 2000# Hoist Trolley

- 6.2 Clean inside flanges of track with a clean, dry cloth (**do not use any kind of cleaning solution**) to remove grit or debris that may have collected during shipping, storage, or installation.
- 6.3 Be sure end stop is installed opposite the festooning end of bridge/monorail.
- 6.4 Attach hoist to hoist trolley by snapping hoist suspension hook over the trolley saddle clevis pin of hoist trolley.

STEP 7 - FESTOON STACK SECTION INSTALLATION

➔ **TIP:** Festoon stack section allows festooning to stack up at the end of the system, permitting full use of runway/monorail.

7.1 Remove end stop on festooning end of runway/monorail.

➔ **For All Systems With Festoon Gliders, or Systems With Festoon Trolleys and 1000, 2000, or 4000 Series Track (diagram 7A)**

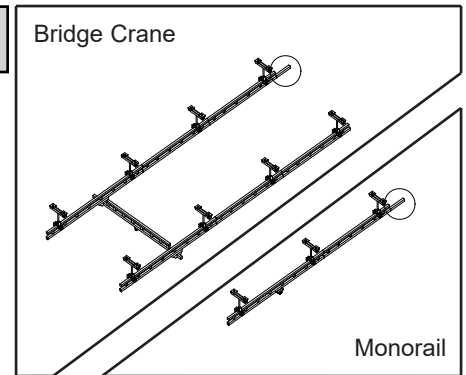
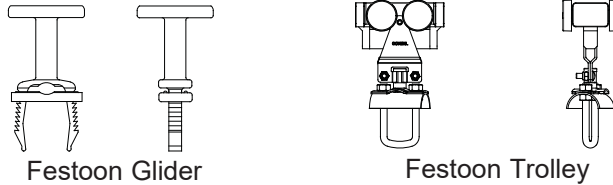

7.2 Slide festoon stack section over open runway/monorail end.

7.3 Re-install end stop (*diagram 7A*).

7.4 Use leveling screws located at top of festoon stack section to align it with the runway/monorail.

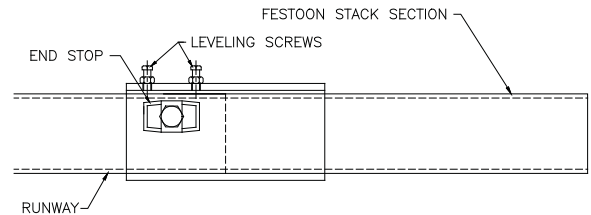

Diagram 7A. Installing festoon stack section.

➔ **For Systems With Festoon Trolleys and 250 or 500 Series Track (diagram 7B)**

Note: Welding is required to attach festoon stack section to runway/monorail when using festoon trolleys with 250 or 500 series track.

7.5 Slide festoon stack section over open runway/monorail end.

WARNING

Do not "over tighten" leveling screws: this will cause permanent damage to the track.

7.6 Use leveling screws located at top of festoon stack section to align it with runway/monorail.

7.7 Weld festoon stack section to runway/monorail at locations (*diagram 7B*).

WARNING

All welds must meet American Welding Society (AWS) specification D1.1 using E70xx electrodes.

Note: Because trolleys are too large to roll under the end stop on the 250 and 500 series track, the end stop and accompanying hardware (which held the festoon stack section to the runway/monorail) is positioned at the end of the festoon stack section. To prevent festoon stack section from sliding off the runway/monorail, the festoon stack section is welded.

7.8 Install end stop (removed in step 7.1) in end of festoon stack section (*diagram 7B*).

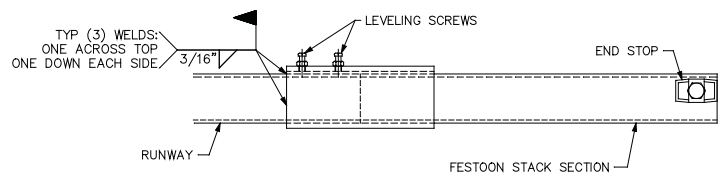

Diagram 7B. Welding festoon stack section on 250-500# series track.

STEP 8 - FESTOONING INSTALLATION

- ➔ **TIP:** Festoon gliders are comprised of a glider body (with upper saddle) and lower saddle (a separate piece that clips onto the glider body).
- ➔ **TIP:** Enough carriers (festoon gliders or festoon trolleys) are supplied to support festoon conductor every 6' on runway/monorail and every 3' on bridges.
Note: Every 6' on vacuum hose trolley.

8.1 If you are using:



festoon gliders, go to Step 8.2 **festoon trolleys**, go to Step 8.7

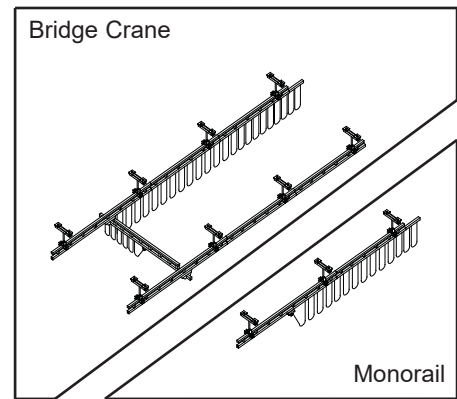

Festoon Gliders (Steel Bridges / Runways only)

If you have a monorail go to Step 8.4.

- 8.2 Slide festoon gliders through end of **bridge** that corresponds with festooning on runway. Space festoon gliders every 3'-0" along bridge.
- 8.3 Slide festoon clamp into place at festooning end of bridge and tighten clamp bolt (**diagram 8A**).
- 8.4 Slide festoon gliders into festoon stack section end of **runway/monorail** track (on festooning side of runway/monorail). Space festoon gliders every 6'-0" along runway/monorail, between bridge and festoon stack section.
- 8.5 Slide festoon clamp into end of runway/monorail/festoon stack section (**diagram 8A**). Tighten clamp bolt until lockwasher is flat.
- 8.6 Proceed to Step 8.15, on page 17.

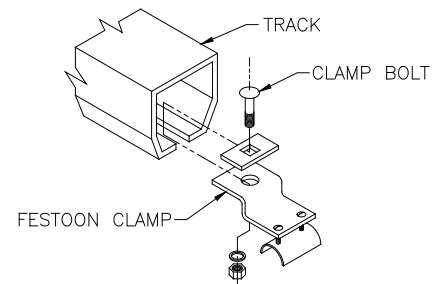

Diagram 8A. Installing festoon clamp on runway or bridge.

Festoon Trolleys

- ➔ **IMPORTANT:** Before installing festoon trolleys in 250 and 500 series track, the molded bumper (on festooning end of bridge runway) must first be removed.

If you have a monorail go to Step 8.11, on page 17.

- 8.7 **For 250-500 series track:**
Remove end stop on festooning end of bridge.
- 8.8 Roll festoon trolleys through open end of **bridge** that corresponds with festooning on runway. Space festoon trolleys every 3'-0" along bridge.
Note: Every 6'-0" for vacuum hose festooning.
- 8.9 Slide festoon clamp/vacuum hose clamp into place at festooning end of bridge and tighten clamp bolt (**diagrams 8A or 8B**).
- 8.10 Re-install end stop (molded bumper with through bolt) in festooning end of bridge (**diagram 8C**, page 17).

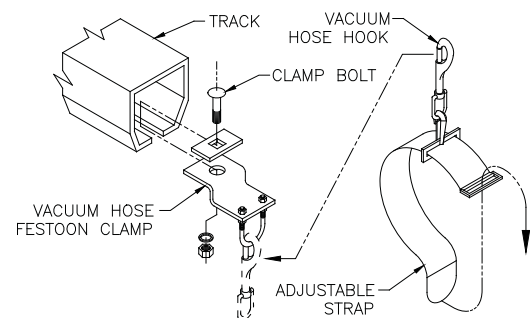

Diagram 8B. Installing vacuum hose clamp on runway or bridge.

STEP 8 - FESTOONING INSTALLATION (CONTINUED)

IMPORTANT: Before installing festoon trolleys in 250 and 500 series track, the molded bumper (on festooning end of bridge runway) must first be removed.

8.11 For 250-500 series track:

Remove end stop from festoon stack section/festooning end of runway/monorail.

8.12 Roll festoon trolleys into end of runway/monorail/festoon stack section track (on festooning side of runway/monorail). Space festoon trolleys every 6'0" along runway/monorail, between bridge and festoon stack section.

8.13 Slide festoon clamp into end of runway/monorail/festoon stack section and tighten clamp bolt (*diagram 8A* or *8B*, on page 16).

8.14 For 250 or 500 series track:

Re-install end stop in runway/monorail/festoon stack section (*diagram 8C*).

8.15 Installing Festoon Electric Cable/Air Hose/Vacuum Hose:

Gliders are designed to accept 4-conductor, electric flat cable (#12 or #14 gauge). Festoon trolleys are designed to accept 4-conductor, electric flat or round cable (#12 or #14 gauge) or air hose (maximum: 7/8" outside diameter).

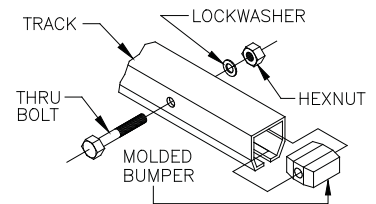

Diagram 8C. Installing end stop on runway/monorail/festoon stack section.

WARNING

Work Station cannot be utilized as a ground: A separate ground wire is required. For example, systems with 3-phase power require 3 conductors plus one ground wire.

Electric Cable with Festoon Gliders

Thread electric cable between upper and lower saddles of glider. Secure electric cable by pushing lower saddle up glider legs, clamping electric cable into place (*diagram 8D*).

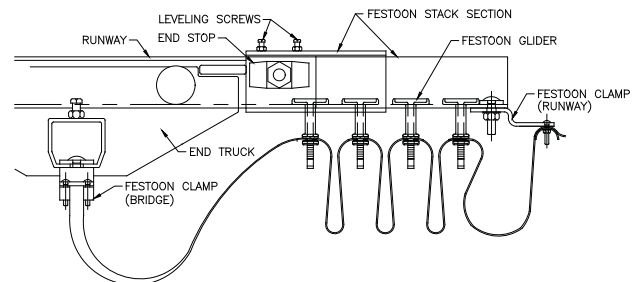

Diagram 8D. Installing electric cable on festoon glider.

Electric Cable/Air Hose with Festoon Trolleys

Loosen nuts and clamp-plate enough to thread electric cable/air hose between the U-bolt legs and clamp plate on festoon trolley. Secure cable by tightening nuts on festoon trolley, forcing clamp plate snug against electric cable/air hose (*diagram 8E*).

Note: Be careful not to tighten nuts too tight; will cause damage to electric cable/air hose.

Note: Be sure that U-bolt does not interfere with trolley body.

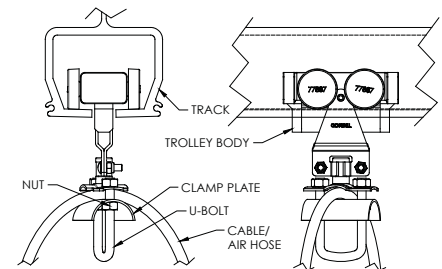

Diagram 8E. Installing electric cable or air hose on festoon trolley.

IMPORTANT: Cable/Air Hose Installation: It is important that as much twist as possible be taken out of the hose before it is hung. To take the twist out follow the steps below:

1. Lay the cable or hose out on the floor flat.
2. Mark the cable or hose where the first end clamp will be and then make marks for trolley and bridge end clamp locations at 6-7 foot intervals. If cable or hose twist still exists, increase intervals.
3. Recoil the cable or hose so that the marks are all lined up on the top of the coiled cable or hose.
4. Lay the large coil on the floor with the marks lined up. At each mark, attach a trolley or end clamp. When installing the festoon, pick up the whole coil and run the trolleys in without disturbing the coil.

Suggestion: Air Swivels should be used at either end of cable or hose to reduce twist.

INSTALLATION PARAMETERS AND APPLIED FORCES TO THE SUPPORTING STRUCTURE

The applied forces drawing in diagram 1, details the relative position and the direction of forces that the work station bridge crane applies to the supporting structure.

Loads applied to the support structure can be determined by the following formulas:

- P = Live Load
- R1 = Vertical Load applied by support hanger (lb.)
- R2 = Longitudinal load applied by movement of the crane to each runway (lb.)
- R3 = Lateral load applied by movement of the trolley and load to each runway (lb.)
- L1 = Maximum distance between hanger centerlines (support centers) (ft)
- L2 = Maximum splice joint centerline to hanger centerline (support center) (in)
- L5 = Maximum bridge cantilever (in)
- L9 = Maximum runway cantilever (in)
- L4 = Bridge span (distance between runway centerlines) (ft)
- 1.4 = Design factor which includes 25% for impact and 15% for hoist weight
- W = Weight per foot of runway (lb./ft)
- w = Weight per foot of bridge (lb./ft)

Note: If there are only 2 hangers per runway substitute "(L1)/2" for "L1" in the R1 formula.

Note: For bridge lengths greater than 23 ft., up to 28 ft., use GLCSL weights. Greater than 28 ft. lengths, up to 34 ft., use GLCSLX weights.

$$R1 = (1.4 * P) + (W * L1) + \frac{(w * L4)}{2}$$

$$R2 = \left[\frac{(1.15 * P) + (w * L4)}{2} \right] * 0.10$$

$$R3 = 1.15 * P * 0.20$$

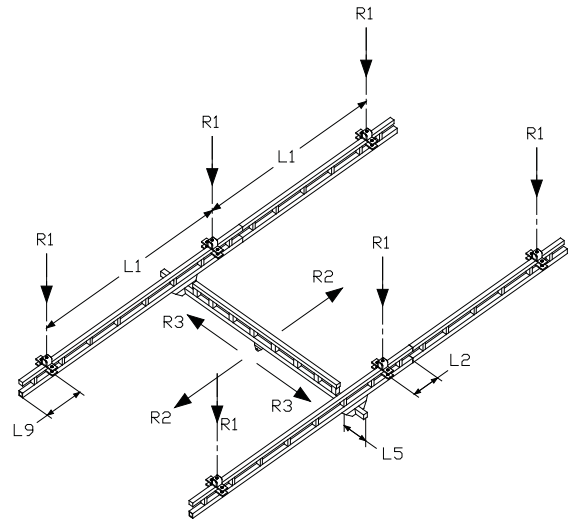

Diagram 1. Applied forces to supporting structure.

INSTALLATION PARAMETERS						
CAPACITY	SERIES	WEIGHT PER FOOT	MAX. L1	MAX. L2	MAX. L5	MAX. L9
250#	GLC	2.53#	6'	8"	18"	18"
	GLCS	4.92#	20'	48"	18"	48"
	AL	4.05#	20'	30"	48"	48"
	GLCSL	8.43#	25'	48"	18"	48"
500#	GLC	4.11#	6'	8"	24"	20"
	GLCS	7.44#	20'	48"	24"	48"
	AL	4.87#	20'	30"	48"	48"
	GLCSL	10.71#	25'	48"	24"	48"
1000#	GLCSLX	11.01#	30'	48"	24"	48"
	GLC	6.22#	6'	8"	24"	20"
	GLCS	12.25#	20'	48"	24"	48"
	AL	8.36#	20'	30"	48"	48"
2000#	GLCSL	14.08#	25'	48"	24"	48"
	GLCSLX	17.47#	30'	48"	24"	48"
	GLC	9.12#	6'	8"	24"	24"
	GLCS	16.89#	20'	48"	24"	48"
4000#	AL	10.01#	20'	30"	48"	48"
	GLCSL	19.36#	25'	48"	24"	48"
	GLCSLX	20.13#	30'	48"	24"	48"
	GLC	9.12#	6'	8"	24"	24"
4000#	GLCS	20.68#	20'	48"	24"	48"
	GLCSL	26.21#	25'	48"	24"	48"
	GLCSLX	28.22#	30'	48"	24"	48"

SWAY AND THRUST BRACING GUIDELINES

➔ TIP: Sway bracing is not required on systems with flush mounted hangers.

WARNING
Bracing must be installed to resist damaging lateral and longitudinal loads.

Sway bracing must be located at or near each support location. It is required that each sway brace point shall not exceed the smaller of 10% of the spacing between supports or 24 inches from a support point. Maximum spacing shall not exceed 30 feet or as determined by structural analysis involving maximum unbraced length of the compression flange, and the horizontal length and horizontal deflection limit of the track.

Thrust bracing must be located at or near end hanger locations. It is required that each thrust brace point shall not exceed the smaller of the 10% of the spacing between supports or 24 inches from a support point. At a minimum, there should be two thrust braces per enclosed track runway. At curved locations (used with monorails) bracing shall be provided at ends and midpoint of curves, but the maximum spacing shall not exceed three feet. On monorail systems, track switches shall be braced in both directions.

Sway or thrust bracing must not be directly attached to hanger rods. All new bracing connecting to the flange of the track and flanges of building beams shall use sway brackets or equal as shown in **diagram 1**. When attaching bracing to steel truss or steel beams, the bracing member shall be attached to the top chord or top flange and located as close to the bridging members as possible.

Angle of bracing from vertical preferably should be equal to or greater than 45 degrees, but in no case be less than 30 degrees.

Generally, bracing is placed either parallel or perpendicular to track. However, skewed bracing is also permissible to accommodate difficult connections, such as the presence of ducts or pipes. Design of skewed bracing should use the same criteria for parallel/perpendicular bracing. For skewed thrust bracing, two pieces, symmetrical to the track, should be used if the skewed angle is greater than 10 degrees.

ANGLE AND PIPE BRACE TYPES Based on (KL/r = 300) Design Criteria

Size	Area (in ²)	r (in)	Max. Length (ft)	Allowable Force (kips)
1" Ø pipe SCH 40	0.49	0.421	10.5	0.81
1" Ø pipe SCH 80	0.64	0.407	10.17	1.06
L 2" x 2" x 1/4"	0.94	0.609	9.75	1.56
L 2 1/2" x 2 1/2" x 1/4"	1.19	0.769	12.28	1.98
L 3" x 3" x 1/4"	1.44	0.930	14.80	2.39

K = Effective Length Factor for a Prismatic Member (see AISC manual)
L = Length of Brace
r = Radius of Gyration

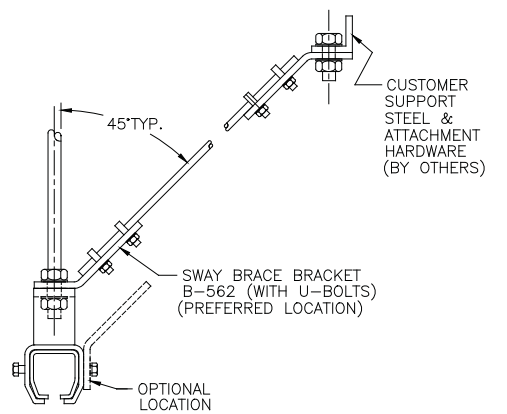
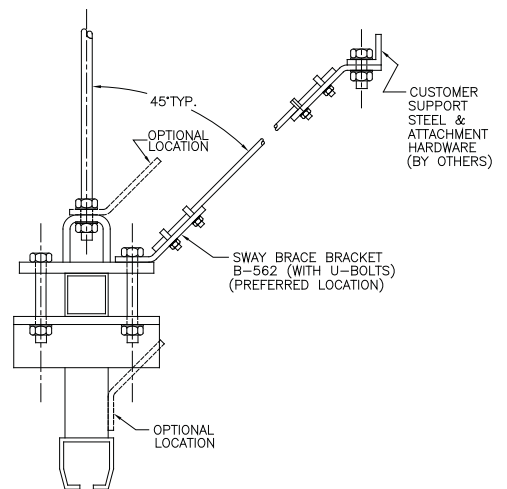
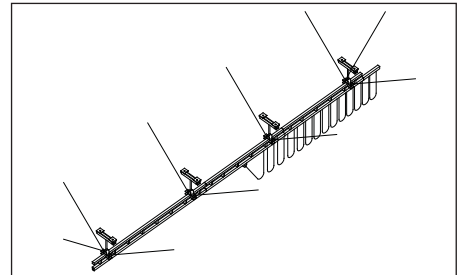
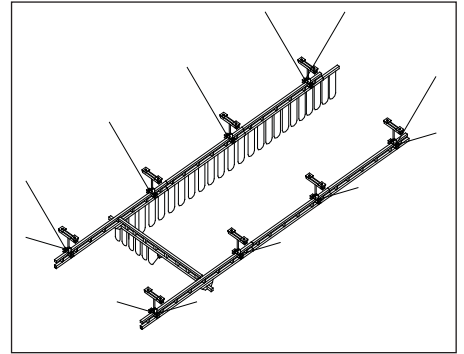

Diagram 1. Typical Connection detail.

LIFT OPERATOR INSTRUCTIONS

Overhead Lifts and Work Station generally handle materials over working areas where there are personnel. Therefore, it is important for the Lift Operator to be instructed in the use of the Lift and to understand the severe consequences of careless operation. It is not intended that these suggestions take precedence over existing facility safety rules and regulations or OSHA regulations. However, a thorough study of the following information should provide a better understanding of safe operation and afford a greater margin of safety for people and machinery on the facilities floor. It must be recognized that these are suggestions for the Lift Operator's use. It is the responsibility of the owner to make personnel aware of all federal, state and local rules and codes, and to make certain operators are properly trained.

Qualifications

Lift operation, to be safe and efficient, requires skill: the exercise of extreme care and good judgment, alertness and concentration, and rigid adherence to proven safety rules and practices as outlined in applicable and current ANSI and OSHA safety standards. In general practice, no person should be permitted to operate a

- Lift:
- Who cannot speak the appropriate language or read and understand the printed instructions.
 - Who is not of legal age to operate this type of equipment.
 - Whose hearing or eyesight is impaired (unless suitably corrected with good depth perception).
 - Who may be suffering from heart or other ailments which might interfere with the operator's safe performance.
 - Unless the operator has carefully read and studied this operation manual.
 - Unless the operator has been properly instructed.
 - Unless the operator has demonstrated his instructions through practical operation.
 - Unless the operator is familiar with hitching equipment and safe hitching equipment practices.

Handling the Bridge Travel Motion

Before using the bridge of the crane, the operator should be sure the hook is high enough to clear any obstruction. Before a load is handled by the Lift, the bridge should be brought into position so that it is directly over the load. Start the bridge slowly and bring it up to speed gradually. Approaching the place where it is desired to stop the bridge, reduce the bridge speed.

Handling the Trolley Motion

Before a load is handled, the hoist should be positioned directly over the load that is to be handled. When the slack is taken out of the slings, if the hoist is not directly over the load, bring it directly over the load before hoisting is continued. Failure to center the hoist over the load may cause the load to swing upon lifting. Always start the trolley motion slowly and reduce the trolley speed gradually.

Handling the Hoist Motion

Refer to the lifting (hoist) equipment's operating instructions.

GENERAL SUGGESTIONS

Know Your Lift

Lift operators should be familiar with the principal parts of a Lift and have a thorough knowledge of Lift control functions and movements. The Lift operator should be required to know the location and proper operation of the main conductor disconnecting means for all power to the attachments on the Lift.

Responsibility

Each Lift operator should be held directly responsible for the safe operation of the Lift. Whenever there is any doubt as to SAFETY, the Lift operator should stop the Lift and refuse to handle loads until: (1) safety has been assured or (2) the operator has been ordered to proceed by the supervisor, who then assumes all responsibility for the SAFETY of the lift.

Do not permit **ANYONE** to ride on the hook or a load.

Inspection

Test the Lift movement and any attachments on the Lift at the beginning of each shift. Whenever the operator finds anything wrong or apparently wrong, the problem should be reported immediately to the proper supervisor and appropriate corrective action taken.

Operating Suggestions

One measure of a good Lift operator is the smoothness of the crane operation. The good Lift operator should know and follow these proven suggestions for safe, efficient Lift handling.

1. The Lift should be moved smoothly and gradually to avoid abrupt, jerky movements of the load. Slack must be removed from the sling and hoisting ropes before the load is lifted.
2. Center the Lift over the load before starting the hoist to avoid swinging the load as the lift is started. Loads should not be swung by the Lift to reach areas not under the lift.
3. Nylon Lifting Straps should be kept vertical. Lifts shall not be used for side pulls.
4. Be sure everyone in the immediate area is clear of the load and aware that a load is being moved.
5. Do not make lifts beyond the rated load capacity of the Lift, Nylon Lifting Straps, GlideteCs, Head sling, Casket Straps, etc.
6. Make certain that before moving the load, Nylon Lifting Straps, GlideteCs, Head sling, Casket Straps or other lifting devices are fully seated in the saddle of the hook with hook latch closed (if equipped with hook latch).
7. Check to be sure that the load is lifted high enough to clear all obstructions when moving Lift or trolley.
8. At no time should a load be left suspended from the Lift unless the operator has the push button with the power on, and under this condition keep the load as close as possible to the floor or table to minimize the possibility of an injury if the load should drop. When the Lift is holding a load, the Lift operator should remain at the push button.
9. Do not lift loads with Nylon Lifting hooks hanging loose. If all Nylon Lifting hooks are not needed, they should be properly stored. (dangling straps or hooks can inadvertently snag other objects when the Lift is moving).
10. Operators shall not carry loads over personnel.
11. Whenever the operator leaves the Lift the following procedure should be followed:
 - Raise all hooks to an intermediate position.
 - Park the Lift at an approved designated location.
 - Place all controls in the "off" position.
 - Make visual check before leaving the Lift.
12. In the case of emergency or during inspection, repairing, cleaning or lubrication, a warning sign or signal should be displayed and the main switch should be in the "off" position or unplugged. This should be done whether the work is being done by the lift operator or by others.
13. Contact with rotation stops or trolley end stops shall be made with extreme caution. The operator should do so with particular care for the safety of persons below the Lift, and only after making certain that any persons on the other Lifts are aware of what is being done.
14. ANY SAFETY FEATURES AND MECHANISMS BUILT-IN OR OTHERWISE PROVIDED WITH THE LIFT BY MORTUARY LIFT ARE REQUIRED FOR THE SAFE OPERATION OF THE LIFT. DO NOT, UNDER ANY CIRCUMSTANCES, REMOVE OR OTHERWISE IMPAIR OR DISABLE THE PROPER FUNCTIONING OF ANY LIFT SAFETY MECHANISMS OR FEATURES BUILT-IN OR OTHERWISE PROVIDED BY MORTUARY LIFT FOR SAFE OPERATION OF THE LIFT. ANY REMOVAL, IMPAIRMENT OR DISABLING OF ANY SUCH SAFETY MECHANISMS OR FEATURES OR OTHER USE OR OPERATION OF THE LIFT WITHOUT THE COMPLETE AND PROPER FUNCTIONING OF ANY SUCH SAFETY MECHANISMS OR FEATURES AUTOMATICALLY AND IMMEDIATELY VOIDS ANY AND ALL EXPRESS AND IMPLIED WARRANTIES OF ANY KIND OR NATURE.

LIMITED WARRANTY

It is agreed that the equipment purchased hereunder is subject to the following LIMITED warranty and no other. Mortuary Lift Incorporated ("MLC") warrants the manual push-pull Work Station, Gantry Crane, and products to be free from defects in material or workmanship for a period of six months parts and labor, 1 years parts, 10 years on the base of the machine from date of shipment. MLC warrants the Work Station products to be free from defects in material or workmanship for a period of six months parts and labor, 1 years parts, 10 years on the base of the machine from the date of shipment. MLC warrants the G-products to be free from defects in material or workmanship for a period of one year from the date of shipment. This warranty does not cover Gantry Crane wheels. This warranty shall not cover failure or defective operation caused by operation in excess of recommended capacities, misuses, negligence or accident, and alteration or repair not authorized by MLC. No system shall be field modified after manufacture without the written authorization of MLC, Inc. Any field modification made to the system without the written authorization of MLC, Inc. shall void MLC's warranty obligation. OTHER THAN AS SET FORTH HEREIN, NO OTHER EXPRESS WARRANTIES, AND NO IMPLIED WARRANTIES, ORAL OR WRITTEN, INCLUDING BUT NOT LIMITED TO THE WARRANTIES OF MERCHANTABILITY OR FITNESS FOR A PARTICULAR PURPOSE, ARE MADE BY MORTUARY LIFT WITH RESPECT TO ITS PRODUCTS AND ALL SUCH WARRANTIES ARE HEREBY SPECIFICALLY DISCLAIMED. MORTUARY LIFT SHALL NOT BE LIABLE UNDER ANY CIRCUMSTANCES FOR ANY INCIDENTAL, SPECIAL AND/OR CONSEQUENTIAL DAMAGES WHATSOEVER, WHETHER OR NOT FORESEEABLE, INCLUDING BUT NOT LIMITED TO DAMAGES FOR LOST PROFITS AND ALL SUCH INCIDENTAL, SPECIAL AND/OR CONSEQUENTIAL DAMAGES ARE HEREBY ALSO SPECIFICALLY DISCLAIMED. MLC's obligation and Purchaser's or end user's sole remedy under this warranty is limited to the replacement or repair of MLC's products at the factory, or at the discretion of MLC, at a location designated by MLC. Purchaser or end user shall be solely responsible for all freight and transportation costs incurred in connection with any warranty work provided by MLC hereunder. MLC will not be liable for any loss, injury or damage to persons or property, nor for damages of any kind resulting from failure or defective operation of any materials or equipment furnished hereunder. Components and accessories not manufactured by MLC are not included in this warranty. Purchaser's or end user's remedy for components and accessories not manufactured by MLC is limited to and determined by the terms and conditions of the warranty provided by the respective manufacturers of such components and accessories.

A) DISCLAIMER OF IMPLIED WARRANTY OF MERCHANTABILITY

Mortuary Lift and Purchaser agree that the implied warranty of merchantability is excluded from this transaction and shall not apply to the goods involved in this transaction.

B) DISCLAIMER OF IMPLIED WARRANTY OF FITNESS FOR PARTICULAR PURPOSE

Mortuary Lift and Purchaser agree that the implied warranty of fitness for particular purpose is excluded from this transaction and shall not apply to the goods involved in this transaction.

C) DISCLAIMER OF EXPRESS WARRANTY

Mortuary Lift agents, or dealer's agents, or distributor's agents may have made oral statements about the machinery and equipment described in this transaction. Such statements do not constitute warranties, and Purchaser agrees not to rely on such statements. Purchaser also agrees that such statements are not part of this transaction.

D) DISCLAIMER OF SPECIAL, INCIDENTAL AND CONSEQUENTIAL DAMAGES

Mortuary Lift and Purchaser agree that any claim made by Purchaser which is inconsistent with MLC's obligations and the warranty remedies provided with MLC's products, and in particular, special, incidental and consequential damages, are expressly excluded.

E) DEALER OR DISTRIBUTOR NOT AN AGENT

Mortuary Lift and Purchaser agree that Purchaser has been put on notice that dealer or distributor is not MLC's agent in any respect for any reason. Mortuary Lift and Purchaser also agree that Purchaser has been put on notice that dealer or distributor is not authorized to incur any obligations or to make any representations or warranties on MLC's behalf other than those specifically set forth in MLC's warranty provided in connection with its product.

F) MERGER

This warranty agreement constitutes a final and complete written expression of all the terms and conditions of this warranty and is a complete and exclusive statement of those terms.

G) PAINTING

Every crane (excluding components) receives a quality paint job before leaving the factory. Unfortunately, no paint will protect against the abuses received during the transportation process via common carrier. We have included at least one (1) twelve ounce spray can for touchup with each crane ordered (unless special paint was specified). If additional paint is required, contact a Mortuary Lift® Customer Service Representative at 1-800-628-8809.

Title and Ownership:

Title to the machinery and equipment described in the foregoing proposal shall remain with Mortuary Lift and shall not pass to the Purchaser until the full amount herein agreed to be paid has been fully paid in cash.

Claims and Damages:

Unless expressly stated in writing, goods and equipment shall be at Purchaser's risk on and after Seller's delivery in good shipping order to the Carrier. MLC shall in no event be held responsible for materials furnished or work performed by any person other than it or its authorized representative or agent.

Cancellations:

If it becomes necessary for the purchaser to cancel this order wholly or in part, he shall at once so advise Mortuary Lift in writing. Upon receipt of such written notice all work will stop immediately. If the order entails only stock items, a flat restocking charge of 15% of the purchase price will become due and payable by Purchaser to Mortuary Lift. Items purchased specifically for the canceled order shall be charged for in accordance with the cancellation charges of our supplier plus 15% for handling in our factory. The cost of material and/or labor expended in general fabrication for the order shall be charged for on the basis of total costs to Mortuary Lift up to the time of cancellation plus 15%.

Returns:

No equipment, materials or parts may be returned to Mortuary Lift without express permission in writing to do so.

Extra Charge Delay: If Purchaser delays or interrupts progress of Seller's performance, or causes changes to be made, Purchaser agrees to reimburse Mortuary Lift for expense, if any, incident to such delay.

Changes and Alterations:

Mortuary Lift reserves the right to make changes in the details of construction of the equipment, as in its judgment, will be in the interest of the Purchaser; will make any changes in or additions to the equipment which may be agreed upon in writing by the Purchaser; and Mortuary Lift is not obligated to make such changes in products previously sold any customer.

Third Party Action:

Should Mortuary Lift have to resort to third party action to collect any amount due after thirty (30) days from date of invoice, the Purchaser agrees to pay collection costs, reasonable attorney's fees, court costs and legal interest.

OSHA Responsibilities:

Mortuary Lift agrees to fully cooperate with Purchaser in the design, manufacture or procurement of safety features or devices that comply with OSHA regulations. In the event additional equipment or labor shall be furnished by Mortuary Lift, it will be at prices and standard rates then in effect, or as may be mutually agreed upon at the time of the additional installation.

Equal Employment Opportunity:

Mortuary Lift agrees to take affirmative action to ensure equal employment opportunity for all job applicants and employees without regard to race, color, age, religion, sex, national origin, handicap, veteran, or marital status. Mortuary Lift agrees to maintain non-segregated work facilities and comply with rules and regulations of the Secretary of Labor or as otherwise provided by law or Executive Order.

INSPECTION AND MAINTENANCE SCHEDULE

Mortuary Lift WORK STATION CRANE AND MONORAIL: INSPECTION AND MAINTENANCE SCHEDULE			
ITEM	COMPONENT	MAINTENANCE	FREQUENCY*
1	Top Hanger Bracket/Beam Clips/Threaded Rod	Check that lockwashers are compressed and nuts tightened to manufacturer's specifications.	Every 2,000 hours or yearly
2	Lower Hanger Bracket	Check that lockwashers are compressed and nuts tightened to manufacturer's specifications.	Every 2,000 hours or yearly
3	Truss Splice Plate	Check that lockwashers are compressed and nuts tightened to manufacturer's specifications.	Every 2,000 hours or yearly
4	Splice Joint	All bolts should be in contact with track. Check track for alignment and that wheel rolling surface is flush.	Every 2,000 hours or yearly
5	Hoist Trolley	Check clevis pin. Check cotter pin. (Cotter pin should be fully wrapped around clevis pin.) Check clevis bolt and hardware.	Every 2,000 hours or yearly
6	End Stops (runway/bridge/monorail)	Check for full compression of lockwasher. If thru-bolt is exposed, replace endstops.	Every 2,000 hours or yearly
7	Festoon Cable Clamp or Vacuum Hose Clamp	Check for full compression of lockwasher.	Every 2,000 hours or yearly
8	Wheels	Check for cracks, pits, and/or grooves: all of these increase pull forces. If any of these conditions exist, wheels should be replaced.	Every 2,000 hours or yearly
9	Aluminum Bridge Assembly Hardware	Check that lockwashers are compressed and nuts tightened to torque specifications (Chart 2A, page 2). Ensure sheer lug hardware is still in required position and tight.	Every 2,000 hours or yearly
10	End Trucks	Check for proper claming hardware attachment. Ensure correct position on bridge to match specified cantilevers. Inspect end truck wheels following instructions for wheels above. <u>Standard end truck</u> : Make sure body is free of any bent materials, cracked or broken welds. <u>Extended end truck</u> : Check overall condition of tubes. Examine supports for bent materials, cracked or broken welds. Inspect hardware attaching end truck support to tubes. Check wheel plate attachment bolts for any wear and make sure the nylock nut is still in the correct position.	Every 2,000 hours or yearly

*Federal, state and local codes may require inspection and maintenance checks more often. Please check the federal, state and local code manuals in your area.

WARNING

Any changes in rolling effort or unusual noises must be immediately identified and corrected. It is not necessary to lubricate the track or bearings. Lubricating may attract airborne particles and may increase the rolling resistance. (Do not use such substances as WD-40®, silicone sprays, oil or grease on bearings or on track flanges.)

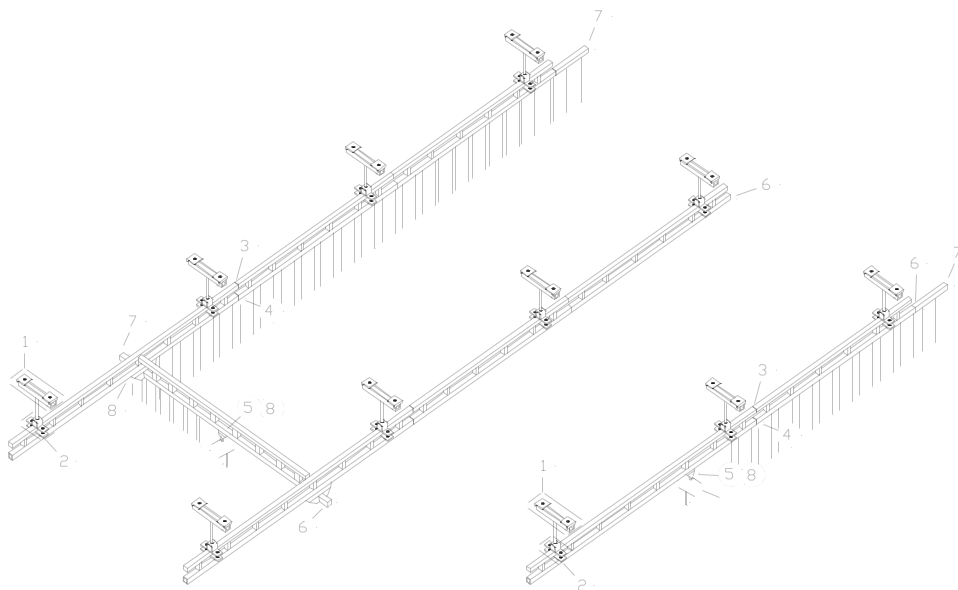

127 Cottage Grove Ave SE,
Cedar Rapids, IA 52403
Phone: (800) 628-8809
Fax: (319) 364-4930
E-Mail: info@mortuarylift.com
http://www.mortuarylift.com

MORTUARY LIFT COMPANY™
A Lifting Experience™



VISIT OUR WEBSITE
www.mortuarylift.com