

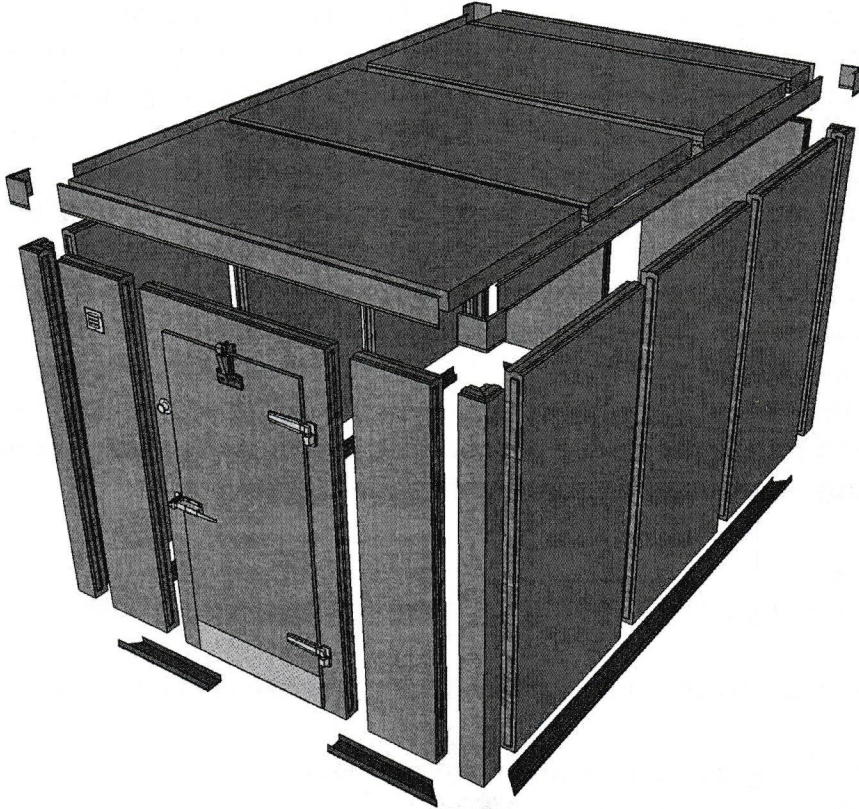

127 Cottage Grove Avenue S.E.
Cedar Rapids, Iowa 52403
800-628-8809 • 319-364-4910
www.mortuarylift.com



Installation Instructions for Coolers/Freezers

NOTE: The following general manual gives information related to the installation of cooler and freezers that are made by Mortuary Lift Company Inc. Some information within this manual may not apply to your specific application, it depends upon what type of product was ordered. Please consult with _____ in regards to your specific application.

1. Receiving Instructions:

Your shipment has been carefully examined, reviewed, and packaged before shipping. We fully expect your order to arrive in satisfactory condition. When the shipment was picked up by the freight company at our facility, it was in proper condition, and at which point it became your property. If there are any damages, noticeable or unnoticeable, they must be reported to the freight company within 15 days of receipt of the shipment at your facility to be able to file a freight claim for damage.

If the damage is noticeable, sign for it as "DAMAGED" on the freight bill and have the driver sign the freight bill as well. Once the freight bill has been signed free and clear, we have no recourse from the carrier on shortages or obvious damages and Mortuary Lift Company Inc. cannot accept responsibility. If there are any questions regarding your order please notify us within 7 days.

If there is damage during transit, but it is not immediately noticeable, leave the item (s) and packing materials "AS IS". Contact your freight company's office and ask for an inspection of the shipment. Also contact Mortuary Lift Company Inc. of your problem.

After inspection has been completed and you have received acknowledgement in writing as to the damages, contact Mortuary Lift Company Inc. for the action you wish to take to fix the issue. **It is your responsibility to follow the above procedures to ensure the freight company and Mortuary Lift Company Inc. will honor any damage claims.**

2. Safety Guidelines:

To avoid possible injury when installing the cooler/freezer, please observe the following safety guidelines:

- Wear personal protective equipment such as: safety glasses, hard hat, gloves, steel toe boots,
- Use proper lifting techniques and handling methods
- Keep work site clear of debris
- Use a certified electrician for any electrical work
- Use a licensed refrigeration company for any refrigeration work
- Follow this installation packet, it is intended to help ensure correct assembly
- If you are uncertain about something contact Mortuary Lift Company Inc. at 319-364-4910

3. General Tools Required:

The tools listed below may be required for installation depending on your application:

- | | | |
|----------------|---|--------------------------------------|
| • Hammer | • NSF approved sealant | • Cordless drill w/ Philips head bit |
| • Tape measure | • Concrete anchors & suitable fasteners | • Tin snips |
| • Chalk line | • Cam wrench (provided) | • Ram set gun or hammer drill |
| • 4' level | • Socket & wrench set | |
| • Miter saw | • Shims | |
| • Caulk gun | | |

4. **Cooler/Freezer Site Preparation:**

We recommend that our coolers be installed on a concrete floor. If you have a freezer without a floor, the concrete will need to be insulated appropriately to prevent any damage from freezing.

Before installing your box, make sure the area where the box is going is clean and clear of any debris, which would cause a poor seal. To ensure a proper installation, it is absolutely crucial that the floor is level. If the building floor is not level, and the unit does not have a cooler/freezer floor, the installer will need to shim under the walls accordingly when installing wall panels. If the floor is not level, and there have been cooler/freezer floors purchased from

Mortuary Lift Company Inc. , the installer will need to begin at the highest point and shim the cooler/freezer floors accordingly. To prevent issues later in the installation process, it is extremely important that your floor is level. Next, check to see if there are any overhead obstacles that would interfere with the installation of the walls of the box, and if so, resolve them before continuing installation. For proper ventilation and to prevent condensation from forming on the exterior of your box, ensure that there is a 2" minimum air gap around all sides of the box, and the top as well. If the 2" air gap is not maintained Mortuary Lift Company Inc. will not cover damages caused by this error.

5. **Floor/Screed Installation Instructions**

It is imperative that the cooler/freezer is installed both level and square. To begin installing the floor screed start by first snapping down a chalk line. Determine a starting point (usually a corner) and make a mark. Remember to maintain the 2" air gap around all walls, when laying out the chalk line for the screed. Then measure out the distance for your base wall line. Measure a line that is the smallest multiple of 4', bigger than the overall length of that wall. Then measure another line perpendicular to the base wall line, at its corresponding multiple of 3'. Use Figure 1 on the next page to check if your lines are square. If not, make any necessary adjustments to the chalk lines, before continuing. Once chalk lines are square make parallel chalk lines at the distances indicated on the screed layout drawing. Check for square one last time. If your lines are square then these will act as the outline for screed installation.

For Coolers & Freezers with Screed: Now line up labeled screed pieces as they are indicated on the screed layout drawing. Do not deviate from the screed layout drawing for a proper installation. Run a 1/4" bead of silicone (provided) under the screed in the center to create a seal (Figure 2). For outdoor applications the installer will need to run an additional bead of silicone to the exterior lip of the screed, after full assembly (Figure 2). Mortuary Lift Company Inc. recommends attaching the screed to the concrete floor using appropriate fasteners (Ram set gun, concrete anchors, etc.). When attaching screed keep in mind that you will need to cut and remove the screed for the door opening later during the install process. It may be easier to precut the screed for the opening, based off the dimensions on the screed layout drawing & overall panel layout. Another option is to cut it out once you've attached it and are setting up the door panel.

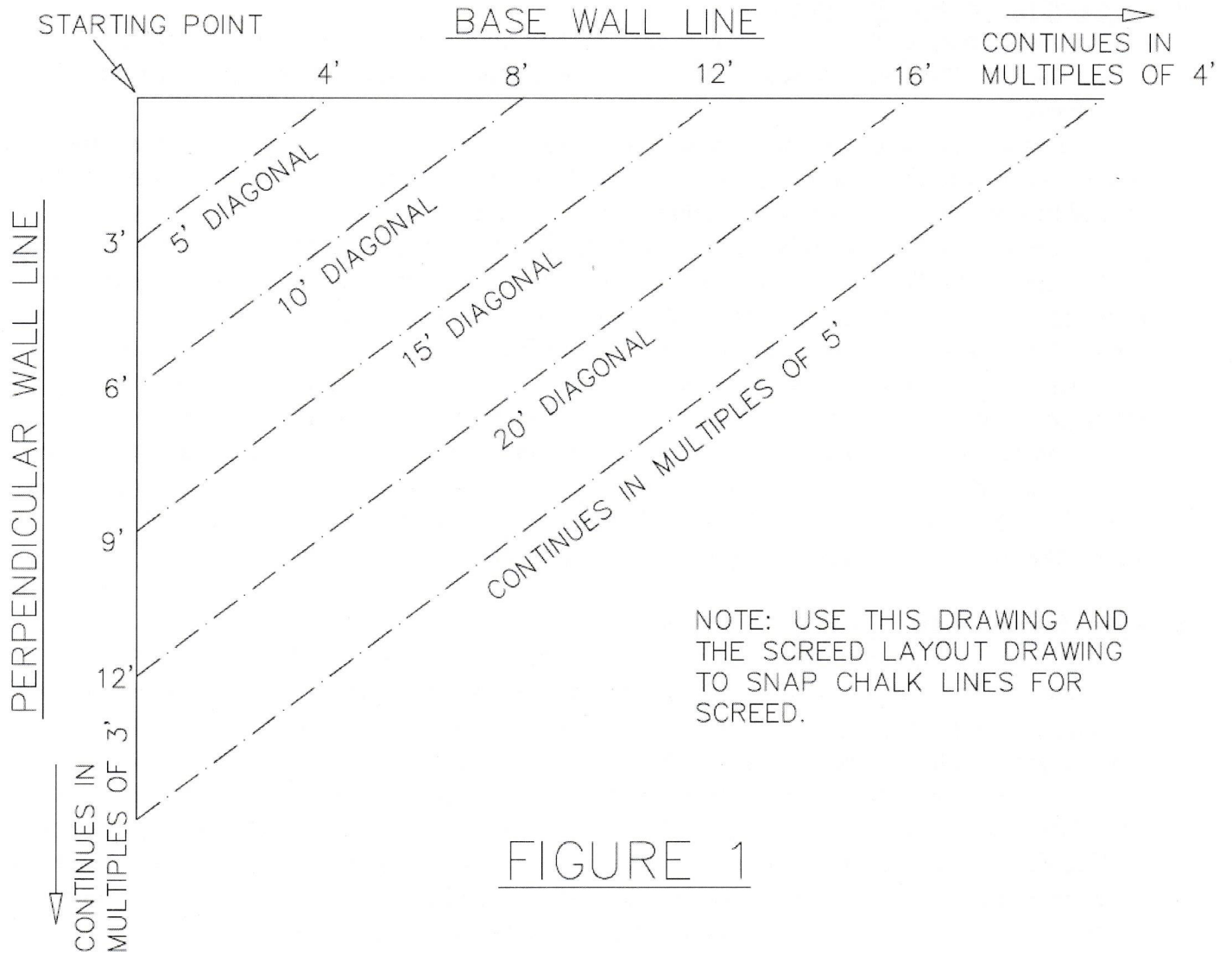

FIGURE 1

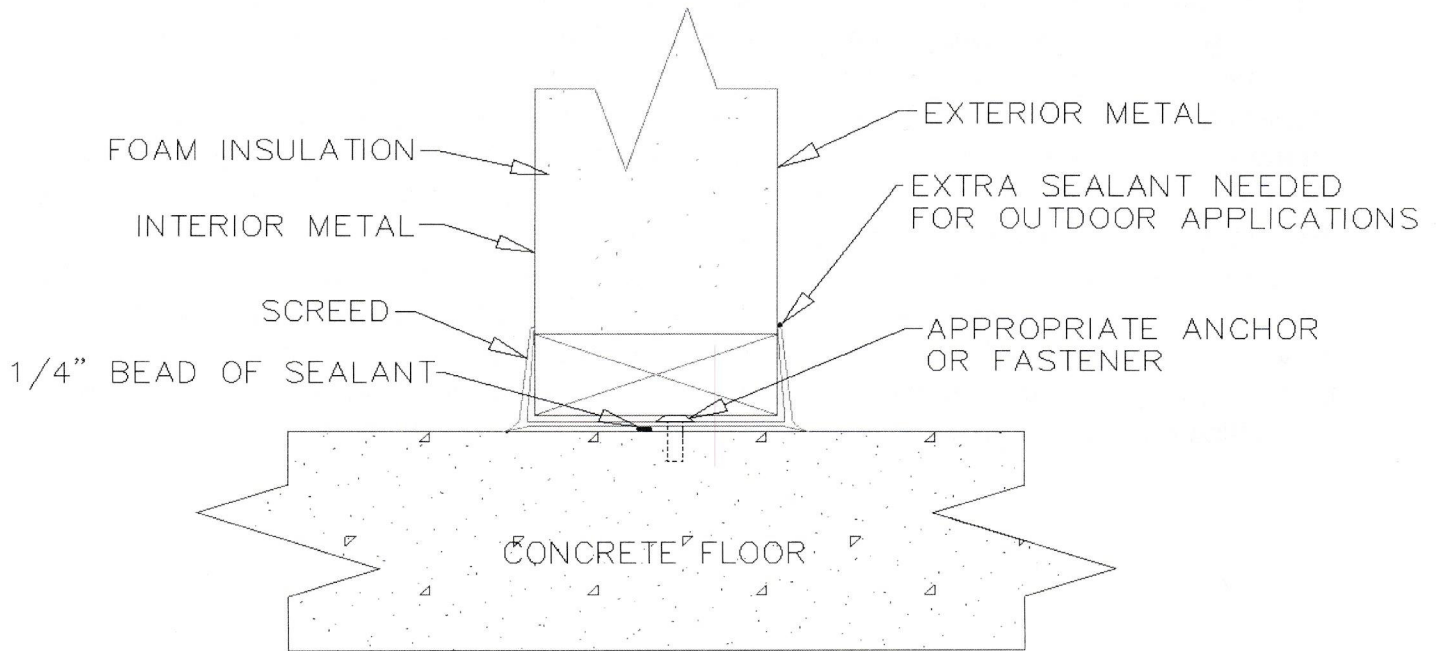

FIGURE 2

For Coolers & Freezers with Floors: If your application has floors made by Mortuary Lift Company Inc. then they will be shipped in panels. Each floor panel has a panel code that corresponds to the overall plan drawing sent with your box. For a correct installation do not deviate from this code. To begin installing the floors start with the floor that would be least accessible if it were the last panel. Place the cooler/freezer floor on your previous outlined mark, and ensure it is level and square. Shim under the cooler/freezer floor if your existing floor is not level. Place another floor down next to the previous (if applicable), and push them towards each other. Make sure they are flush and level, and then lock them together by inserting the Allen wrench into the cam lock hole on the interior side, and then rotating the wrench clockwise until it is fully locked. Continue in this fashion until all floors are locked together. Once all floors are level, square, and locked together, you are now ready to install the wall panels. Pictured below are the wall to floor junctions for a standard floor and a low profile floor for a box with an interior ramp (Figure 3).

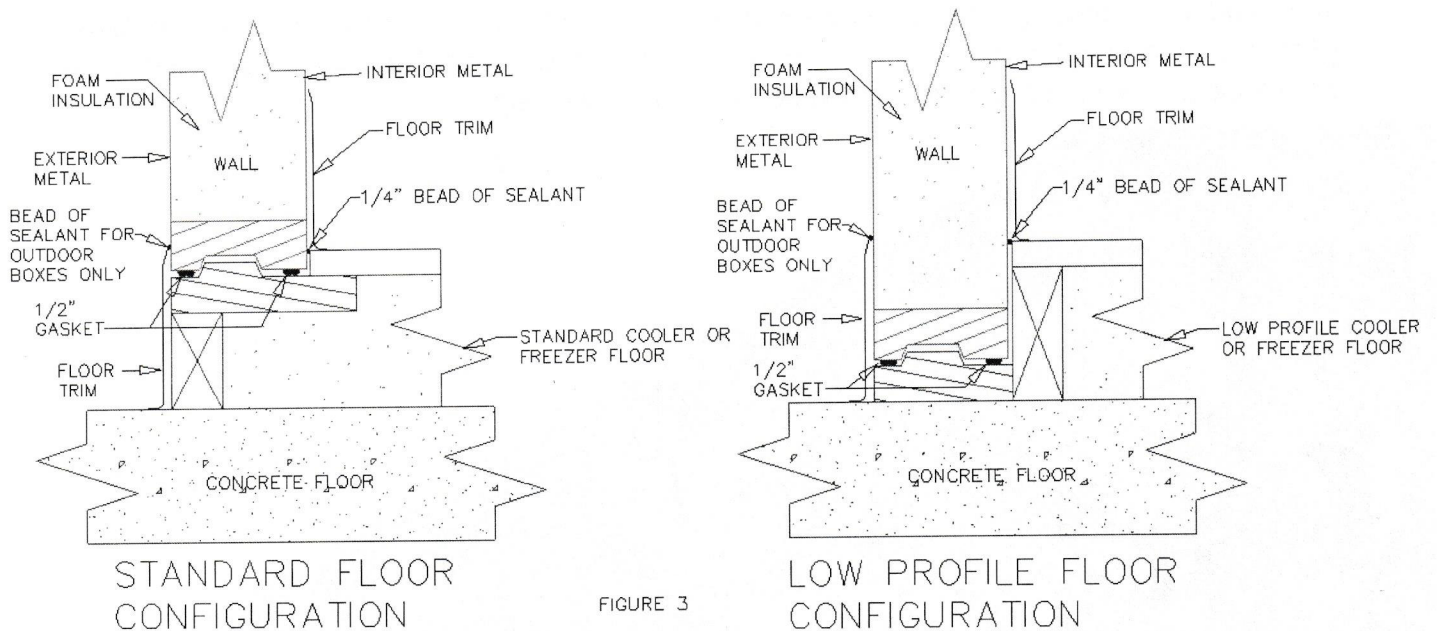

FIGURE 3

6. Wall Installation Instructions

Once your screed/floor is properly installed, you are now ready to begin setting up walls. Each panel is labeled on at least two sides with a panel code. The panel code corresponds with the overall plan drawing sent with the box. Please refer to the overall plan drawing to identify which panels go where. When deciding which panel to set up first, start with the corner panel that would be least accessible upon completion, and work in any direction from there. If your box is a cooler/freezer combination box, and the freezer has a floor, start with the freezer panels before installing the cooler panels. It doesn't matter which way you begin installing the walls, just make sure that a corner is the last panel installed. Begin by setting a corner panel and an appropriate adjacent wall panel, in the screed channel or on the cooler/freezer floor. Before locking these panels together, push them as close together as possible, and check that the top edges of the interior metal on the respective panels are flush and level (Figure 4). If they are not you will need to shim under the wall, within the screed channel or between the wall and the floor, accordingly. Once they are level and flush lock the panels together using the Allen wrench (provided), by inserting the Allen wrench into the cam lock hole on the interior side, and then rotating the wrench clockwise until it is fully locked (Figure 5 & 6). The lock will grab the pin and pull it together, if for some reason this does not happen, simply rearm the cam lock, by rotating it counterclockwise, and then trying again.

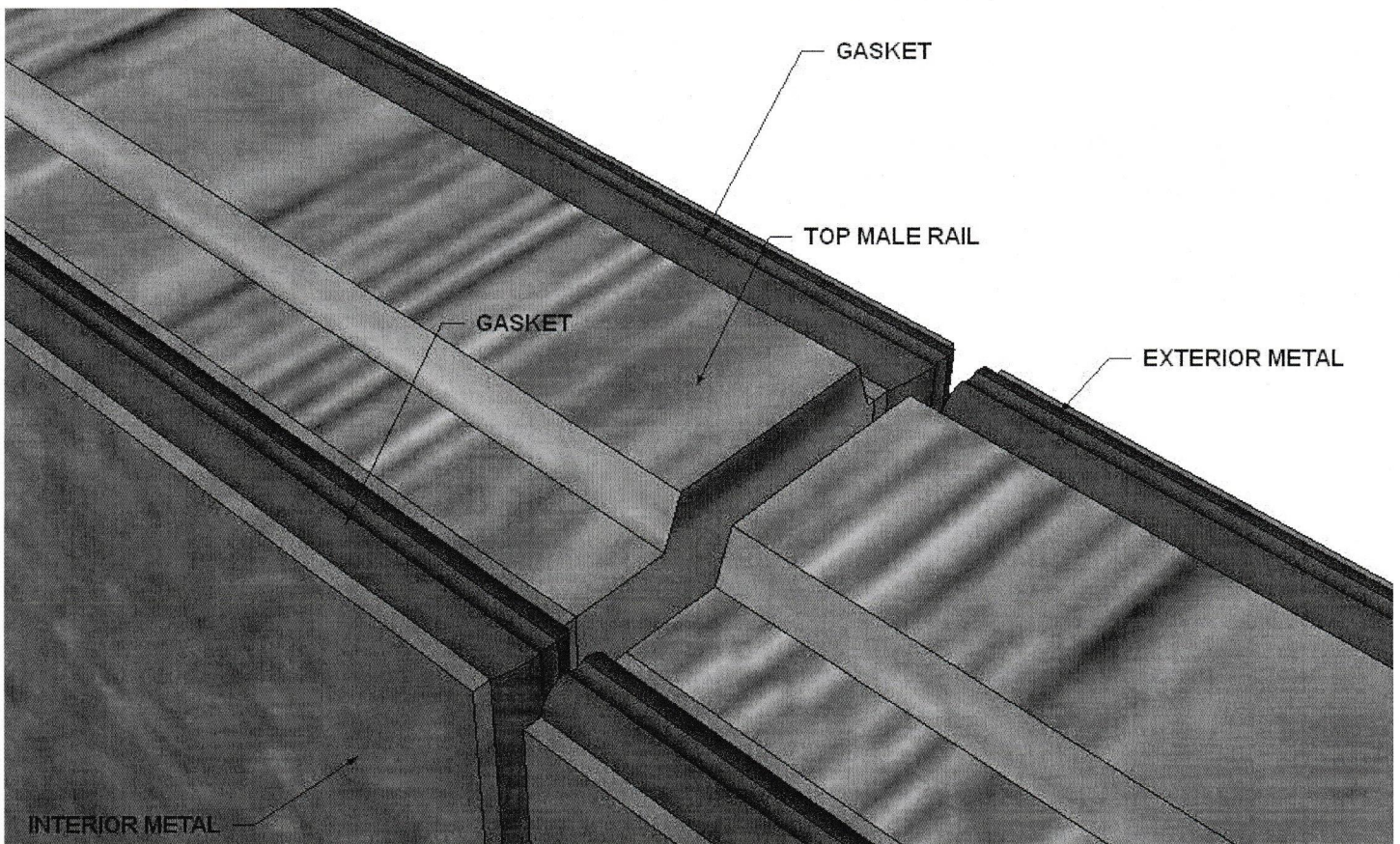

Figure 4

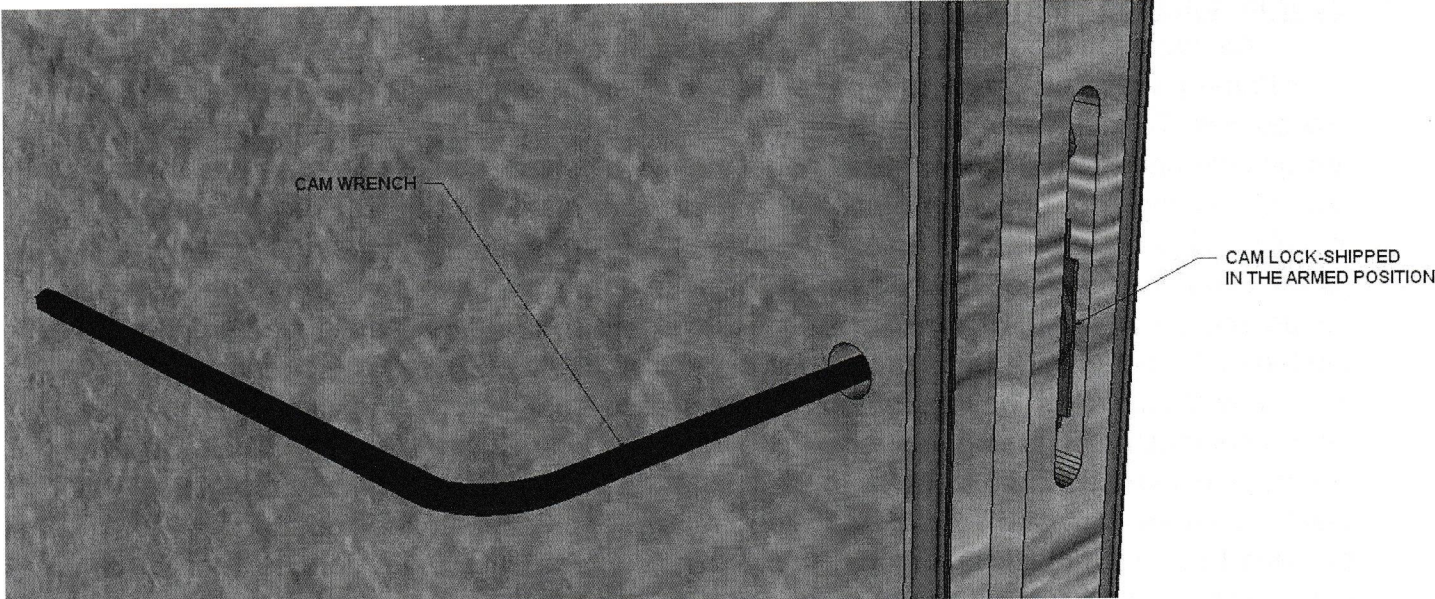

Figure 5

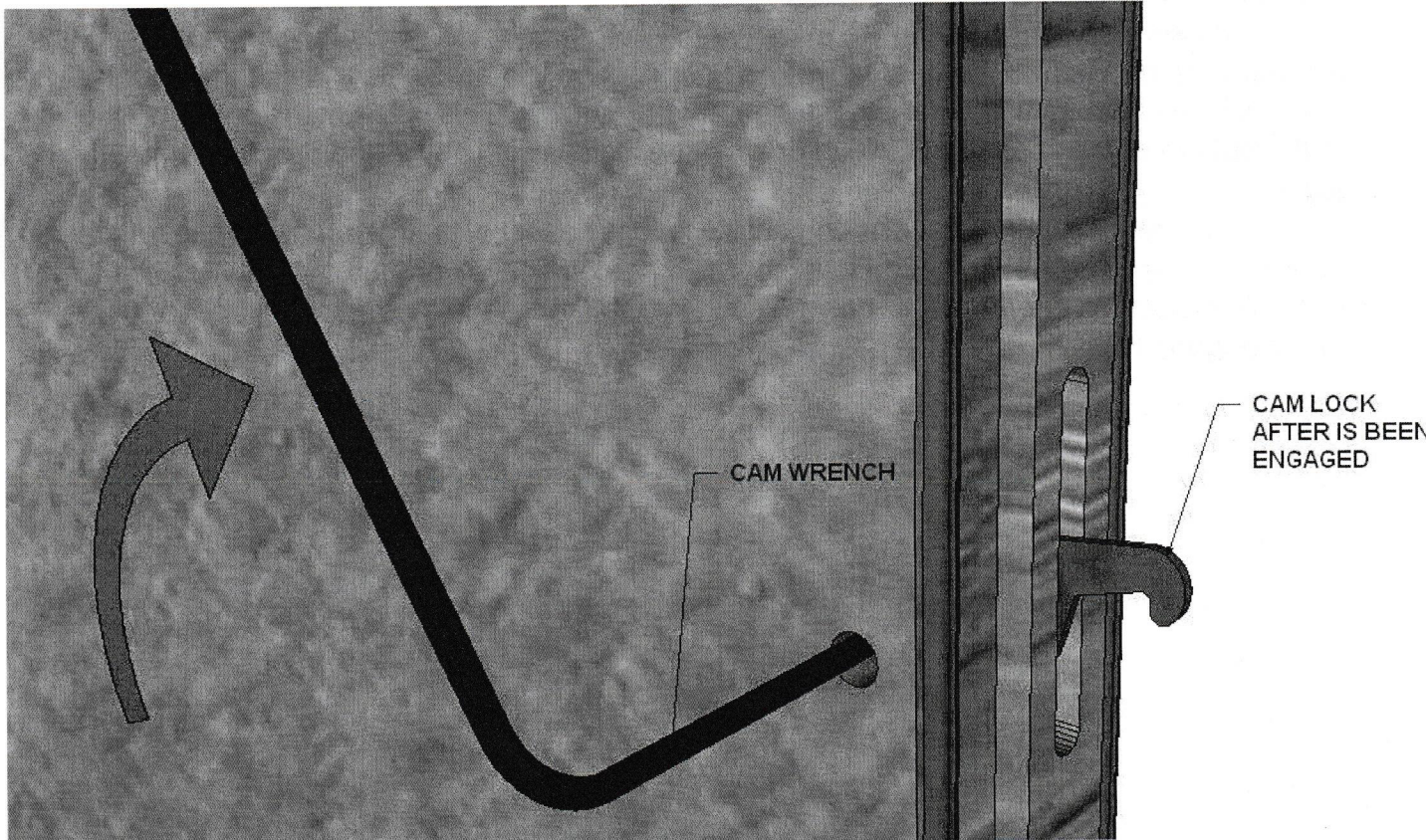

Figure 6

7. Door Installation Instructions

As you continue to set up wall panels you will eventually need to setup the door and door frame panel. The door frame panel installs similarly to the wall panels with a few added procedures. To make the installation of the door and door panel go easier, you may wish to remove the door from the door frame panel that it was shipped in. To do this open the door 90° and then lift the door out of the hinges. Place the door off to the side so you can continue to install the door frame panel. Remove the wood shipping brace off the bottom of the door frame panel. Once the brace is removed **carefully** place door frame panel in screed, and lock it to the adjacent wall panel. Ensure the frame is level and square and check that the dimension of the top of the opening, is the same as the dimension at the bottom of the opening, before anchoring frame. If you have not removed the screed from the opening, do so at this time before continuing. To fasten the door frame to the existing concrete floor, drill holes into the concrete, using the predrilled holes in the anchor brackets as guides. Insert the #14 x 1 1/2" plastic anchors (provided), and then fasten the anchor brackets to the floor using #14 x 1 1/2" pan head screws (provided) (Figure 7). You can now remount the door on the door frame panel, and continue with the install.

Mortuary Lift Company Inc. manufactures three other door configurations, depending on your application. The first is used when a cooler has a floor, or when a combination box has a floor throughout both the cooler and freezer (Figure 8). There will be a screed threshold attached to the floor, and all that is required is to remove the shipping brace and place the door frame panel on the floor. Make sure the legs are tight to the sides of the threshold before locking it to the adjacent wall panels.

The second configuration we manufacture is for coolers & freezers with floors that have an interior ramp through the door way. The floors will be low profile floors, and the door frame panel will have jambs that extend past the frame (Figure 9). This is to ensure a seal all the way to the bottom of the floor. This style of door frame installs similarly to the previously mentioned style.

The final configuration we manufacture is for freezers with floors. This configuration is preferred, when applicable, because it creates a heated seal all around the perimeter of the door. To install this door frame simply place in into the recess in the matching freezer floor panel (Figure 10).

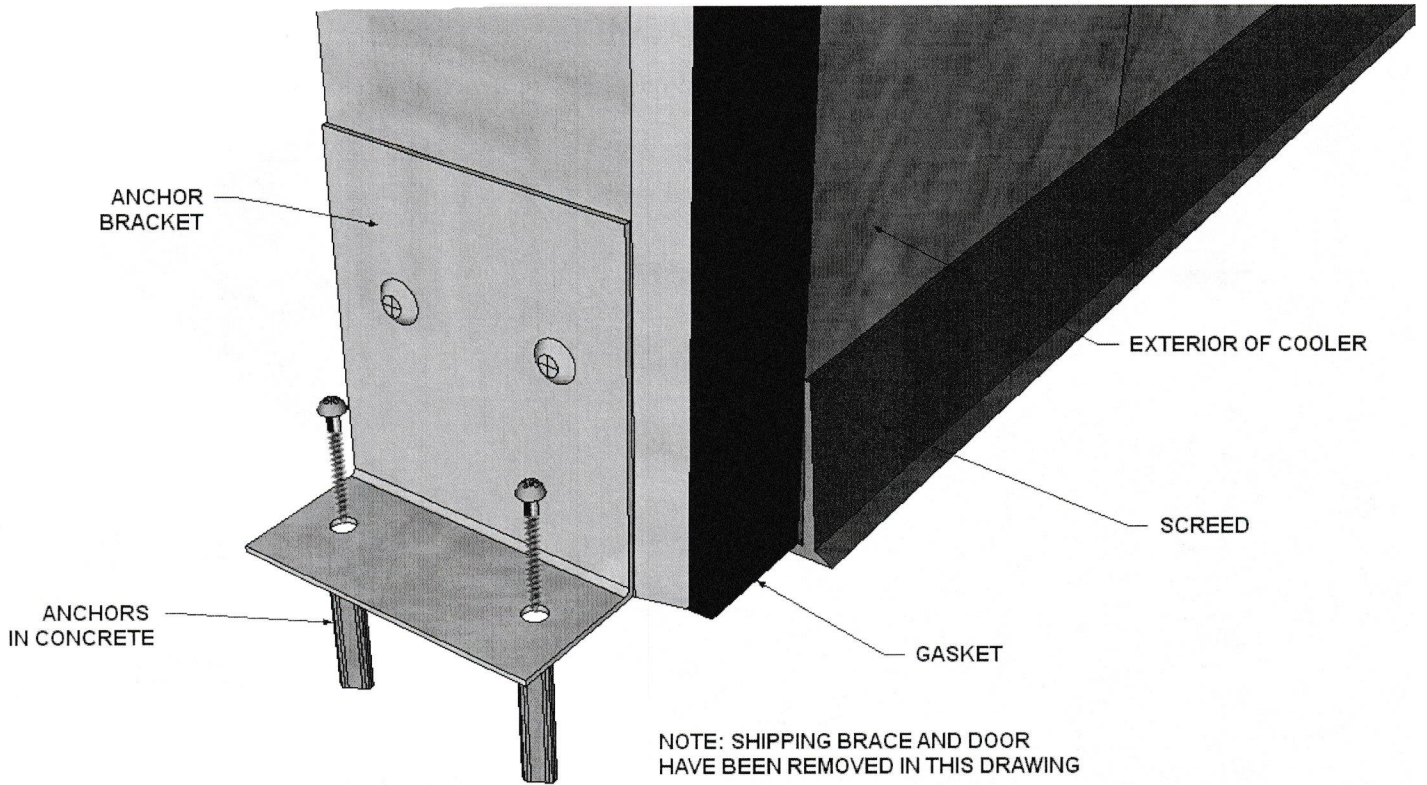

Figure 7 (Door Configuration for Cooler/Freezer with Screed)

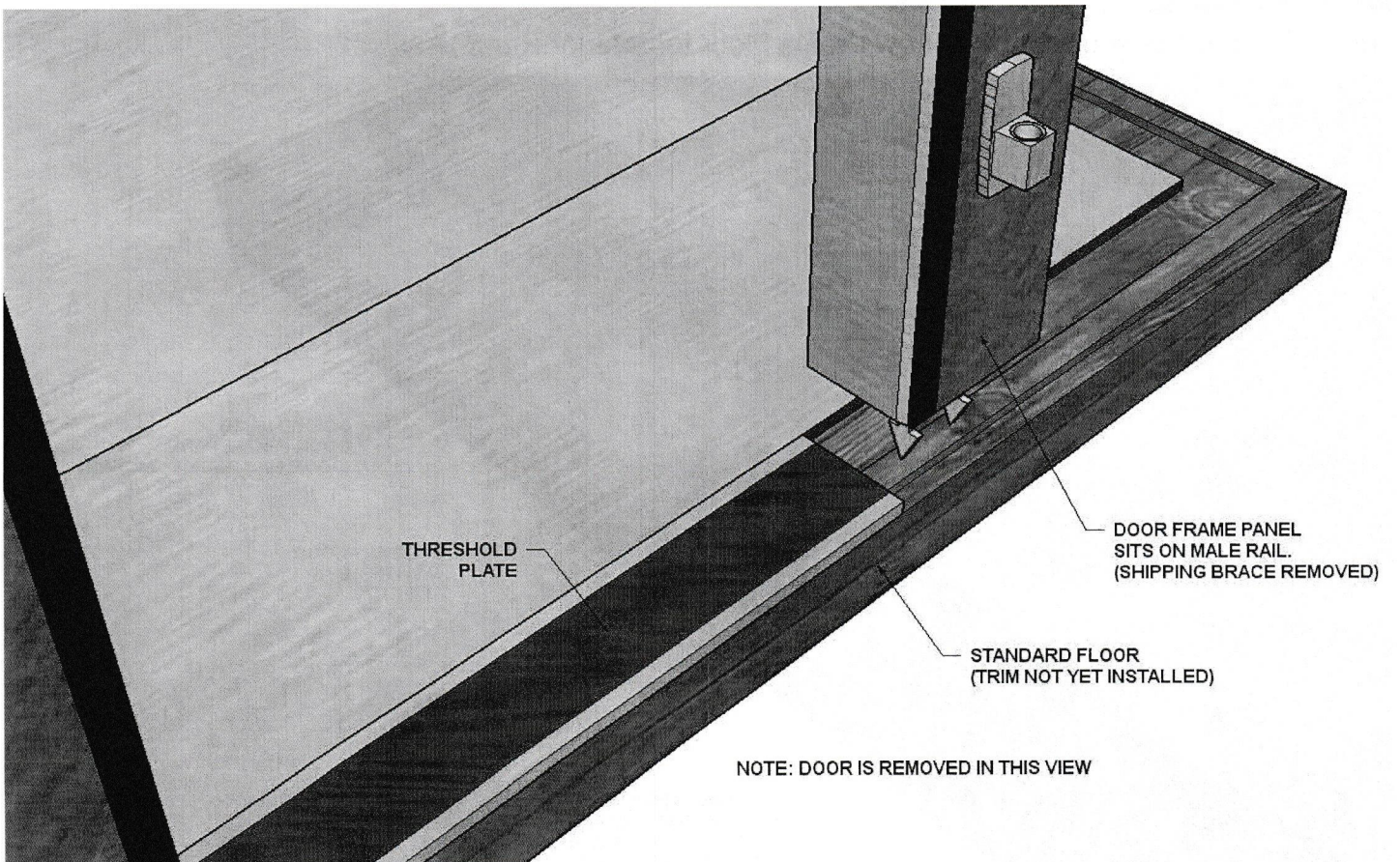

Figure 8 (Door Configuration with Standard Floor)

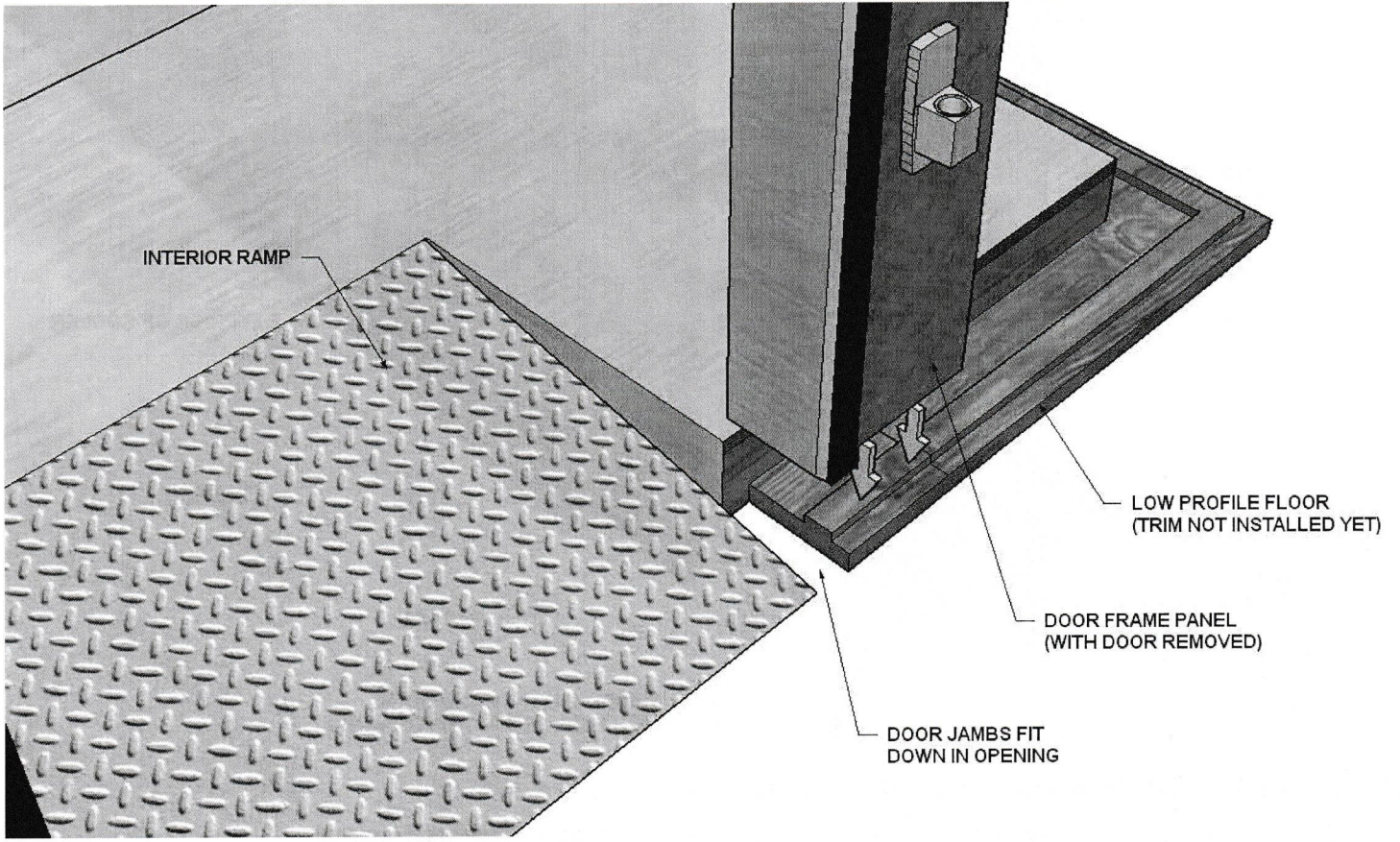

Figure 9 (Door Configuration with Low Profile Floor for Interior Ramp)

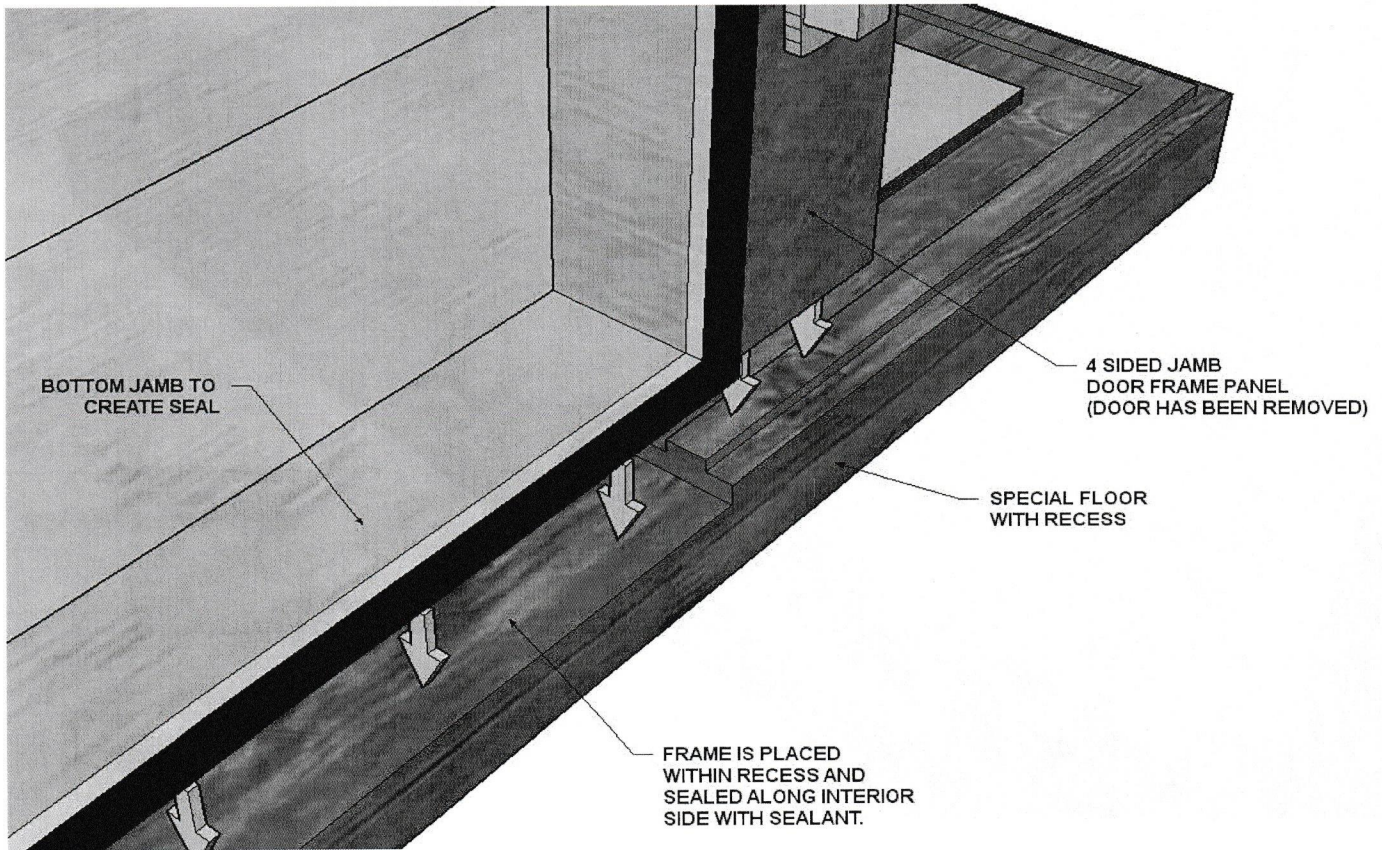

Figure 10 (Door Configuration With 4 Sided Seal)

8. Top/Ceiling Installation Instructions

Mortuary Lift Company Inc. manufactures two ceiling styles, lag down ceilings and cam-down ceilings. Our lag down design is most common. The top panels are designed to sit directly on top of the walls, with the female rail of the tops sitting down on the male rail of the walls. Ensure that you have all walls under a top panel erected before installing that top panel. Again the top panels have a panel code and the code corresponds with the overall plan drawing sent with the box. Please refer to the overall plan drawing to identify which panels go where. Begin with the top that would be the least accessible if it were the last top. Similarly to the wall panels, make sure the tops are flush and level with the other tops before locking together. Once the tops are locked together you will then need to lag them into place, using the lag bolts and washers (provided). Use 5" lags for cooler tops (3 1/2" thick), and 8" lags for freezer panels (5" thick). Simply drop the lag and washer into the predrilled holes, and tighten as needed (Figure 11). If you have access around the entire box you can lock all the tops together and then lag them down, but if you do not, you will have to lag down each top as you go.

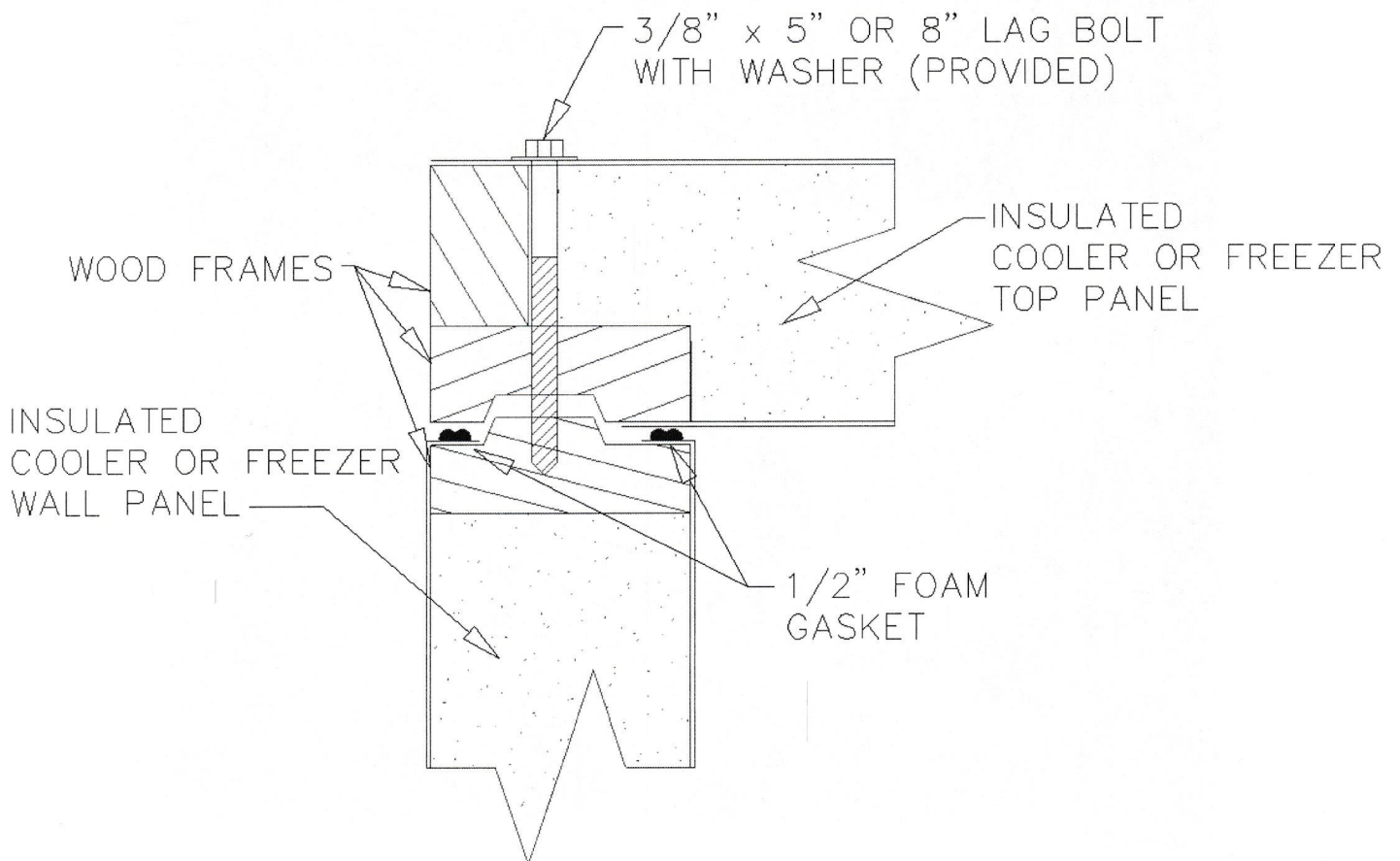

Figure 11

9. Top Support Installation Instructions

Our tops are self-supporting unless the distance they need to span is too long. In this case, we construct multiple tops that lock together to cover the span. However they will need to be supported by other means. Mortuary Lift Company Inc. uses two different means to accomplish this: beam support or hanger bracket support.

Note: Beam not supplied by Mortuary Lift Company Inc.

Beam Support- If you choose to support the tops with beams, the beams will be positioned under the male and female junction, and the cooler or freezer panels lock together like normal (Figure 12).

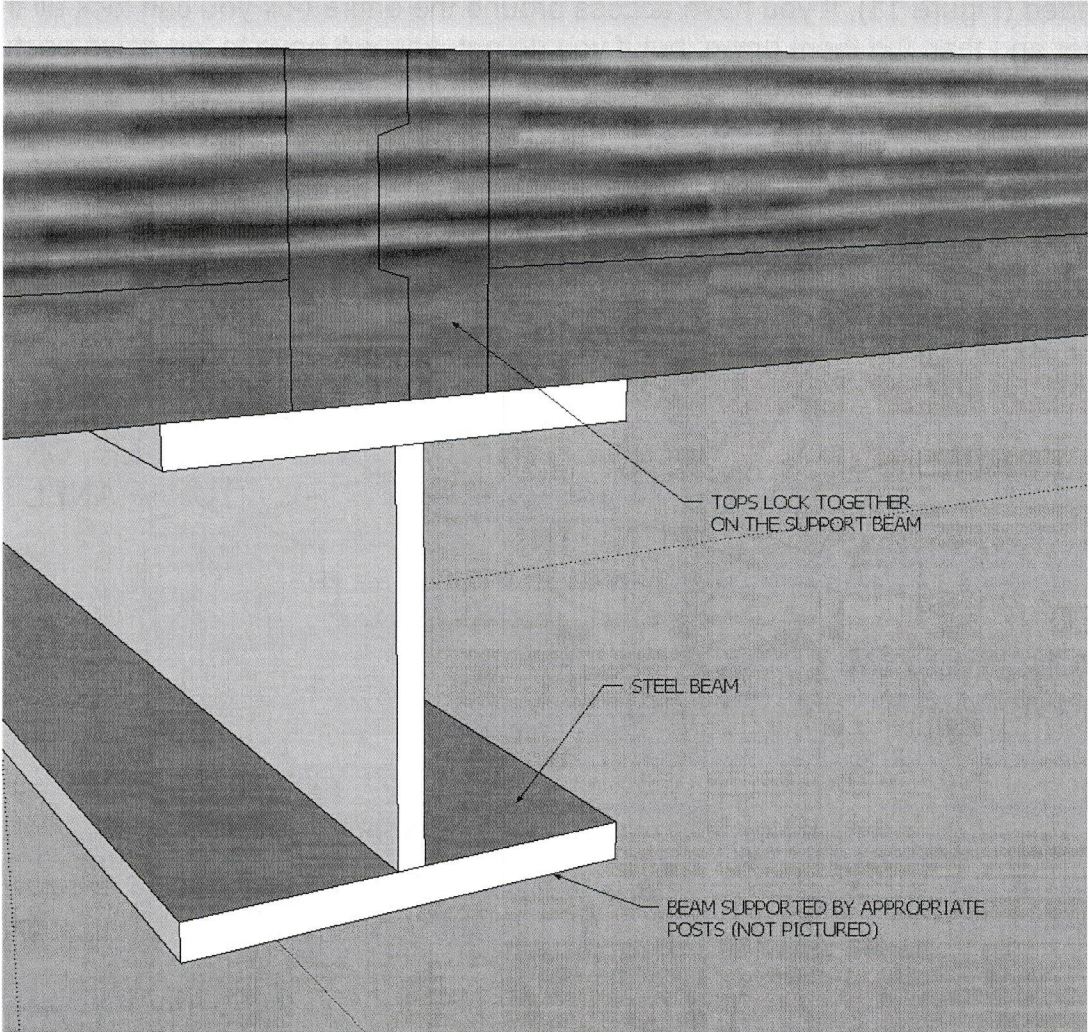

Figure 12

Hanger Bracket Support- The other way to support the tops is with a hanger bracket system. Only the hanger brackets are supplied by Mortuary Lift Company Inc. , all other threaded rod, nuts, bolts, washers, and fasteners need to be furnished by the installer. One hanger bracket is needed between every panel junction. To install the hanger brackets simply fasten a hanger bracket to the female rail using appropriate nails before installing the panel. Once the panel is installed, the threaded rod is attached to the overhead steel structure and the hanger bracket. Adjust the threaded rod as needed so the top is level and the weight of the top is being supported by it (Figure 13 & 14).

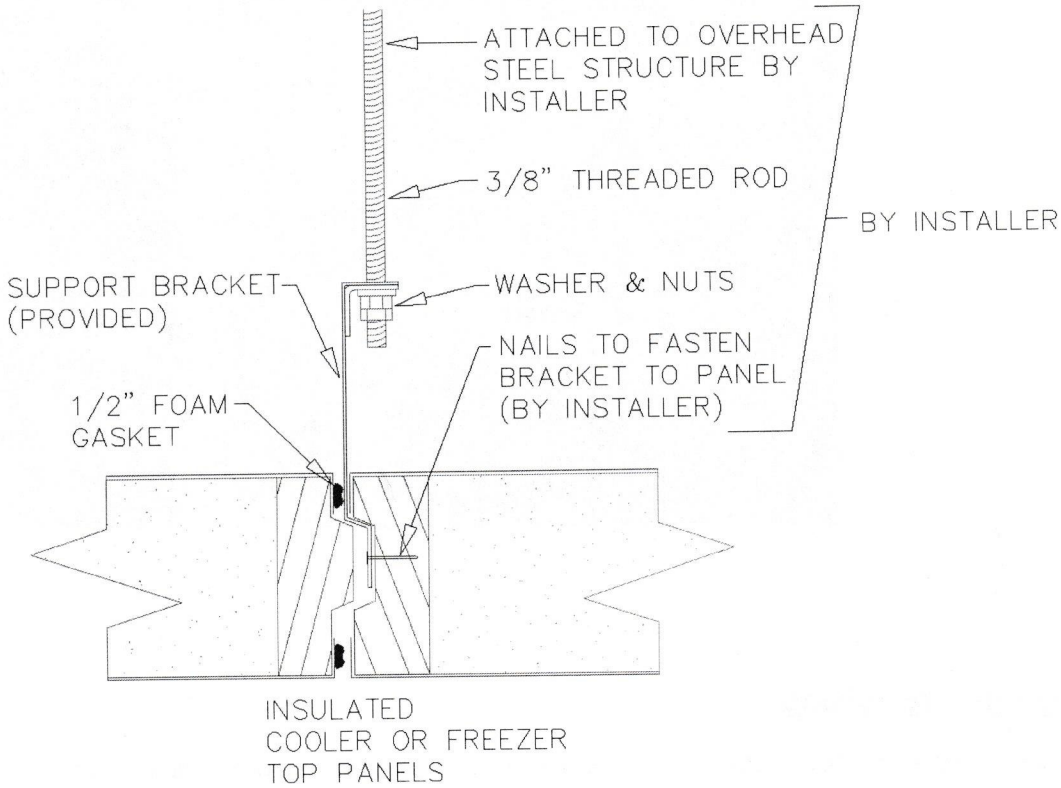
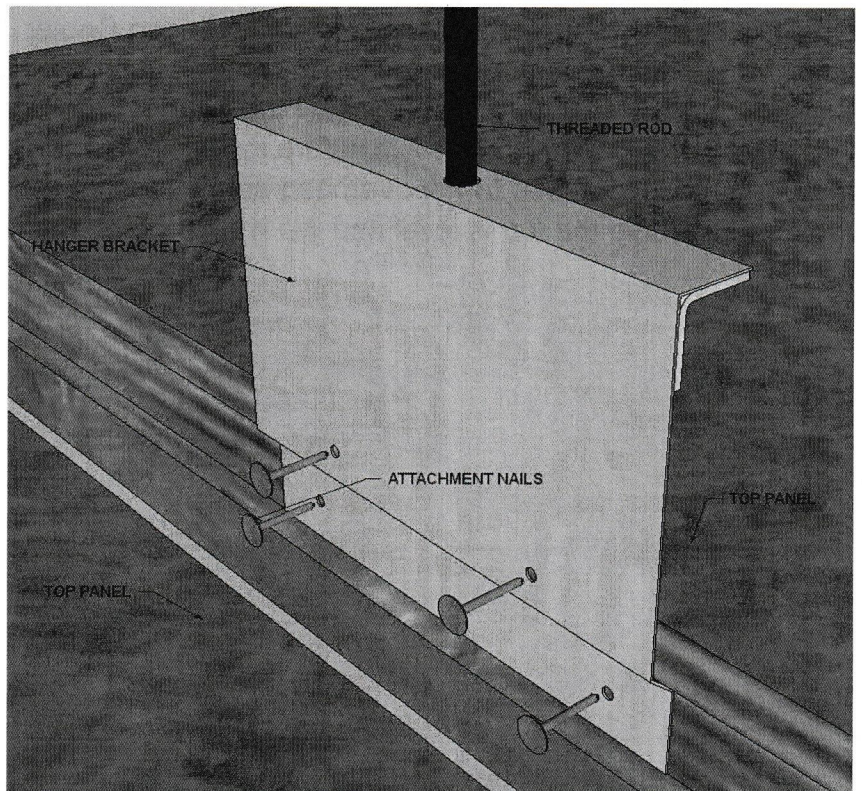

Figure 13

Figure 14



10. Adapter Rail Installation Instructions

Adapter rails are used to incorporate M.L.C.'s panels with existing structures or existing coolers/freezers. Occasionally they will be incorporated into a new unit, please refer to the overall layout to see if this is applicable for your situation. For existing structures, a thermal break may need to be created for optimal performance. First prep & clean the existing surfaces you are going to attach the adapters to. Next identify all adapters required for the specific application, refer to overall layouts for adapter labels and locations. Adapters should be predrilled and countersunk, for 14 x 3 Flat Phil W/S ZNC screws provided by M.L.C. Other fasteners may be needed to fit a different application, M.L.C. only provides fasteners when adapters are incorporated into a new unit. Position adapters as shown on overall layout print, ensure they are level, and attach to existing structure. More fasteners can be used to help keep the adapters square and level, adjust as needed. Once installed, M.L.C. panels can now be attached via the cam lock and pin system, previously described. If needed, a bead of sealant can be applied after installation to help ensure a good seal. Figures 15 and 16 on the next page provide an example.

Figure 15

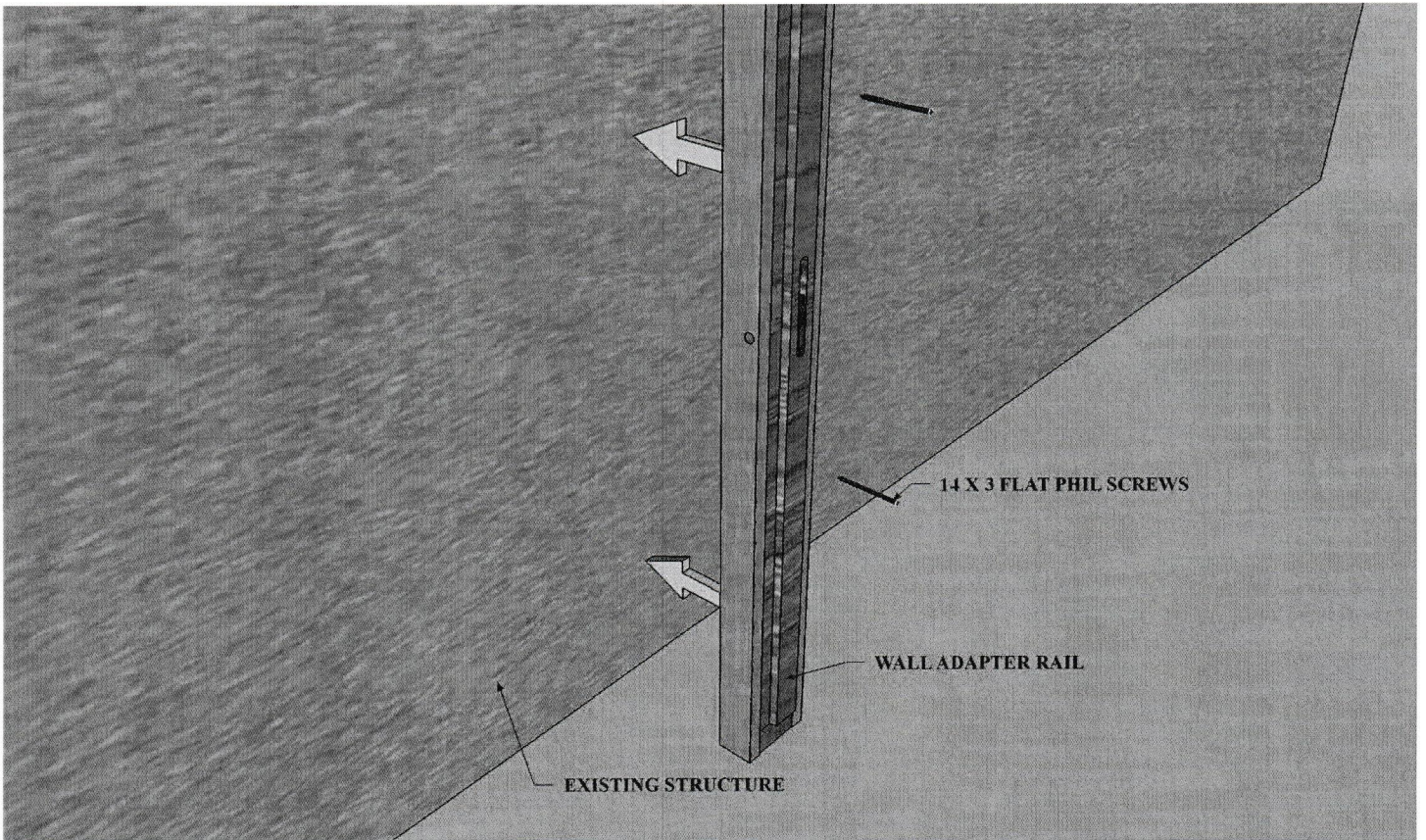
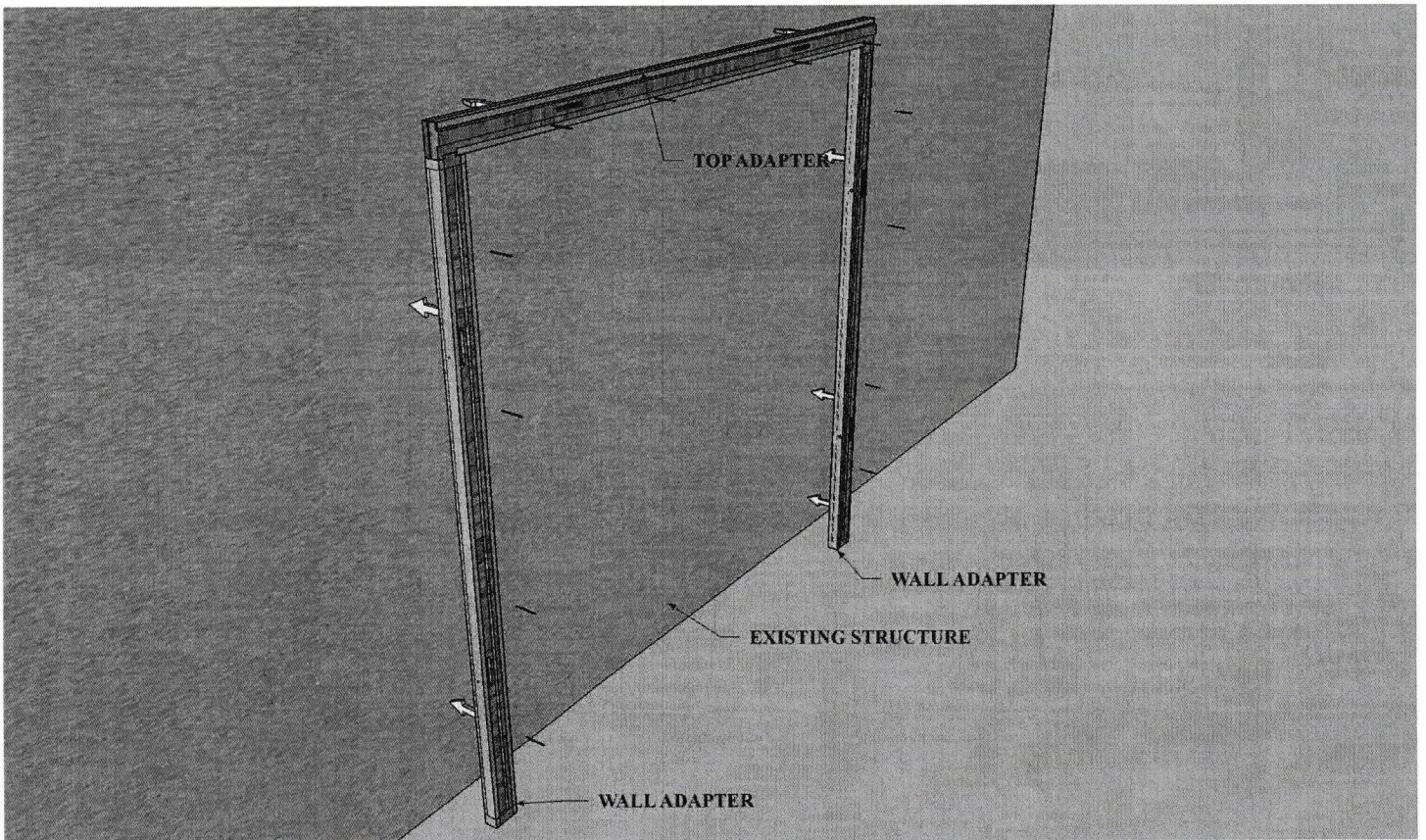

Figure 16 – Example Set of adapters



11. Top Cap Trim Installation Instructions

Top cap trim will be sent with each cooler or freezer to cover any exposed wood around the exterior surface of the top panels. Use the #8-18 x 5/8" pan phil tek znc screws provided by MLC to secure the top trim. Place screws approximately in the middle of the trim when fastening. Space screws every two feet and do not over tighten screws (Figure 17).

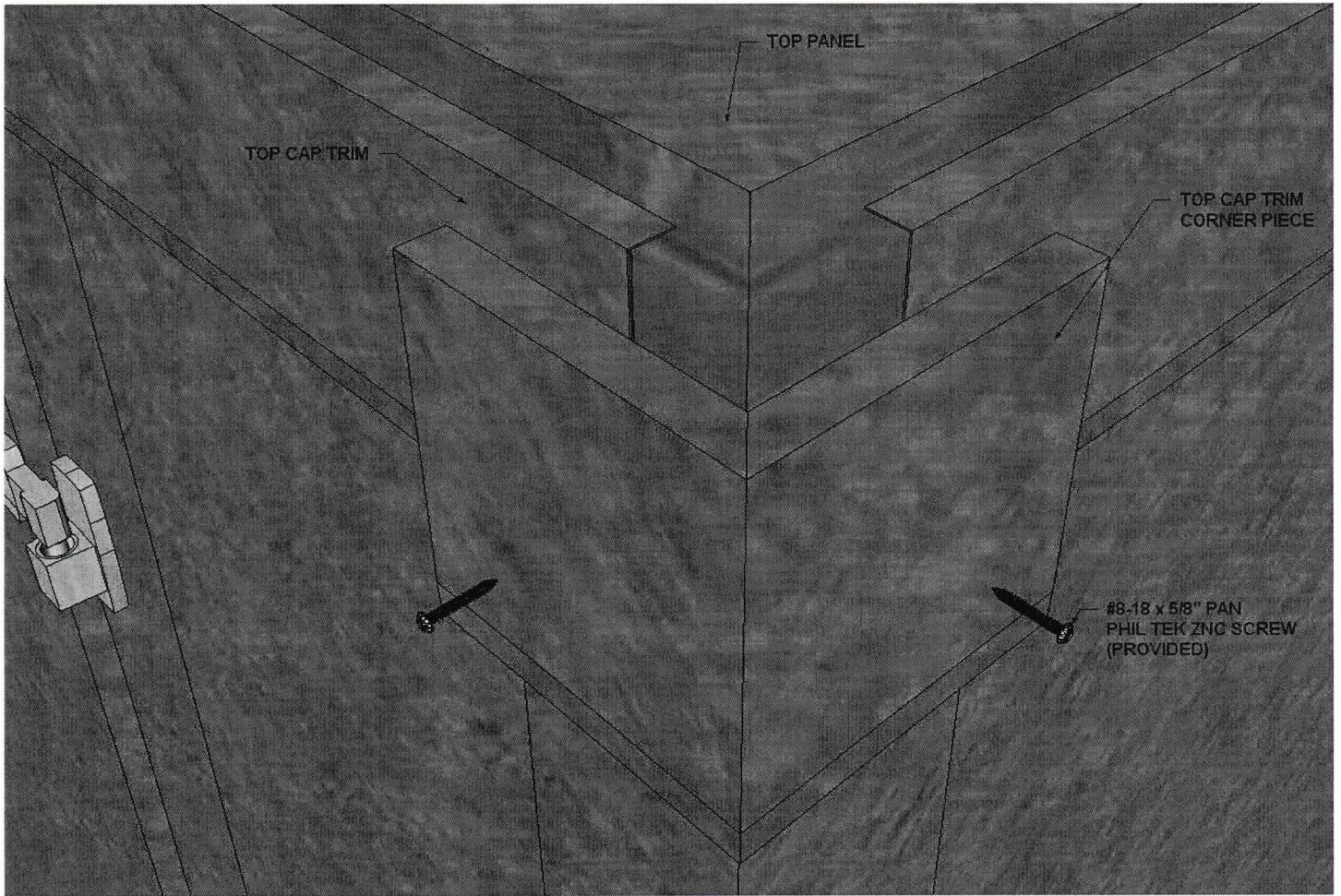

Figure 17

12. Floor Cap Trim Installation Instructions

Floor cap trim will be sent with each cooler or freezer with a floor, to cover any exposed wood around the exterior surface of the floor panels. Floor trim is also sent to finish the interior junction between the floor and walls. Before installing floor cap trim, run a bead of sealant at the wall and floor junction (interior side only required), then cover it with the trim. Use the #8-18 x 5/8" pan phil tek zinc screws provided by MLC to secure the floor trim. Place screws approximately in the middle of the trim when fastening. Space screws every two feet and do not over tighten screws. Exterior trim and exterior corner trim piece are shown in Figure 18.

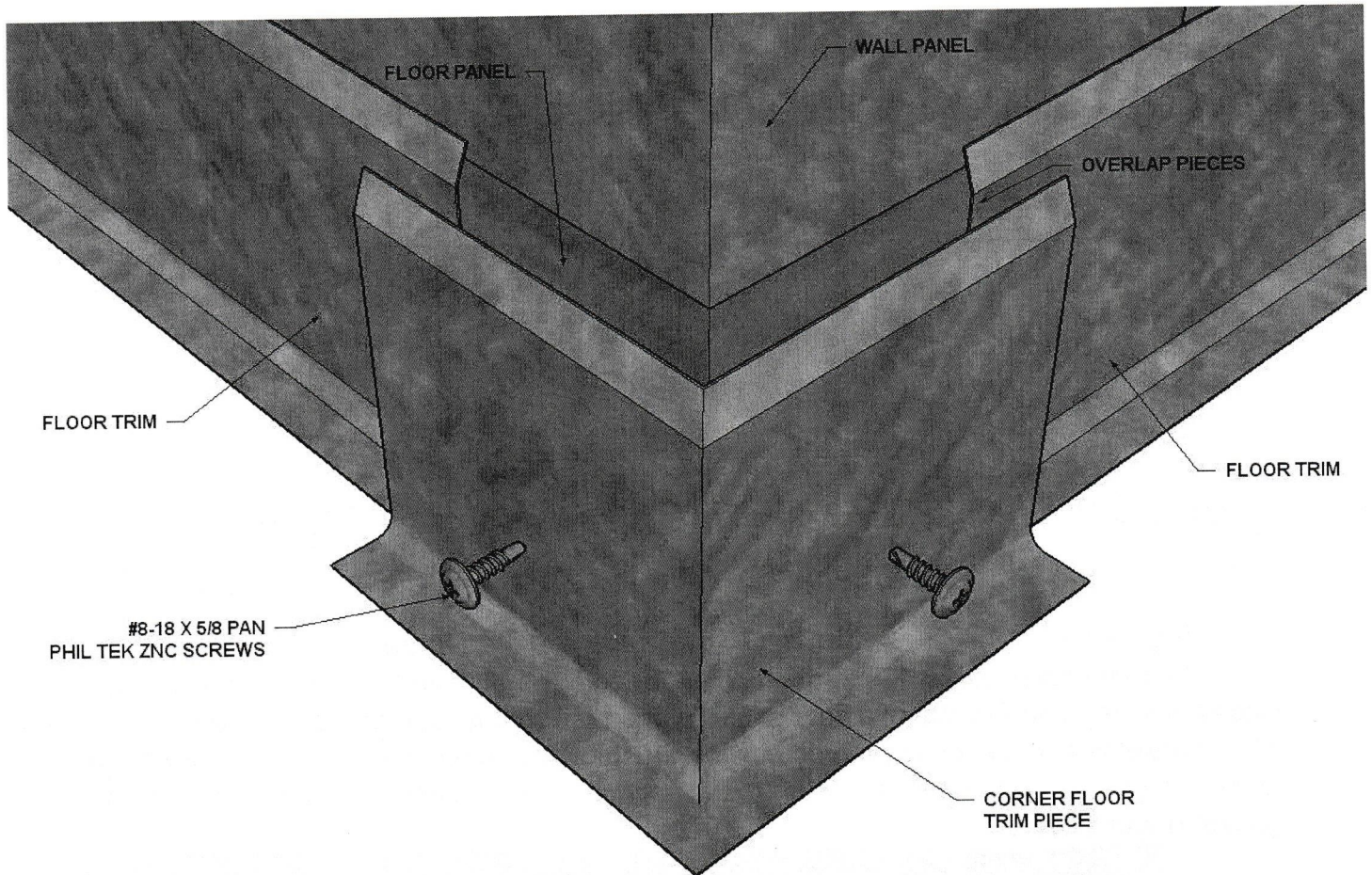

Figure 18

13. Door Sweep Gasket & Strike Adjustment instructions

If you have taken your door off the hinges to install the door frame panel, please reattach it now. If the door has jambs on 3 sides, it will be shipped with a sweep gasket to create a seal on the bottom of the door (If the door has jambs on 4 sides, then disregard this sheet). When the door is shipped from the manufacturer, the sweep gasket is pre-adjusted to approximately 1" long (Figure 19.1). After installing the door and frame, the sweep gasket may need to be adjusted. You want the sweep gasket approximately 1/8" to 1/4" longer than the gap between the bottom of the door and the finished floor (Figure 19.2). To adjust the sweep gasket, you will need to loosen the screws located on the bottom inside of the door. After loosening the screws, you can adjust the sweep gasket up or down as needed. Retighten screws when finished.

BOTTOM OF DOOR
SIDE VIEW (SHIPPED)

BOTTOM OF DOOR
SIDE VIEW (ADJUSTED)

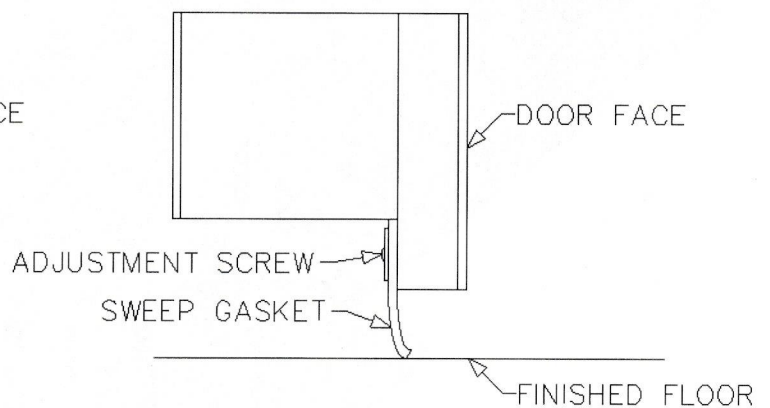
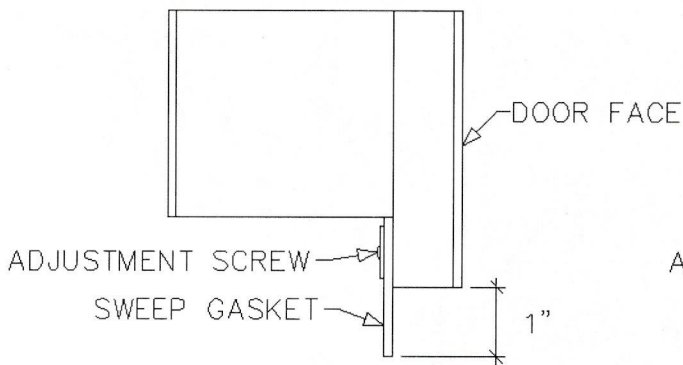
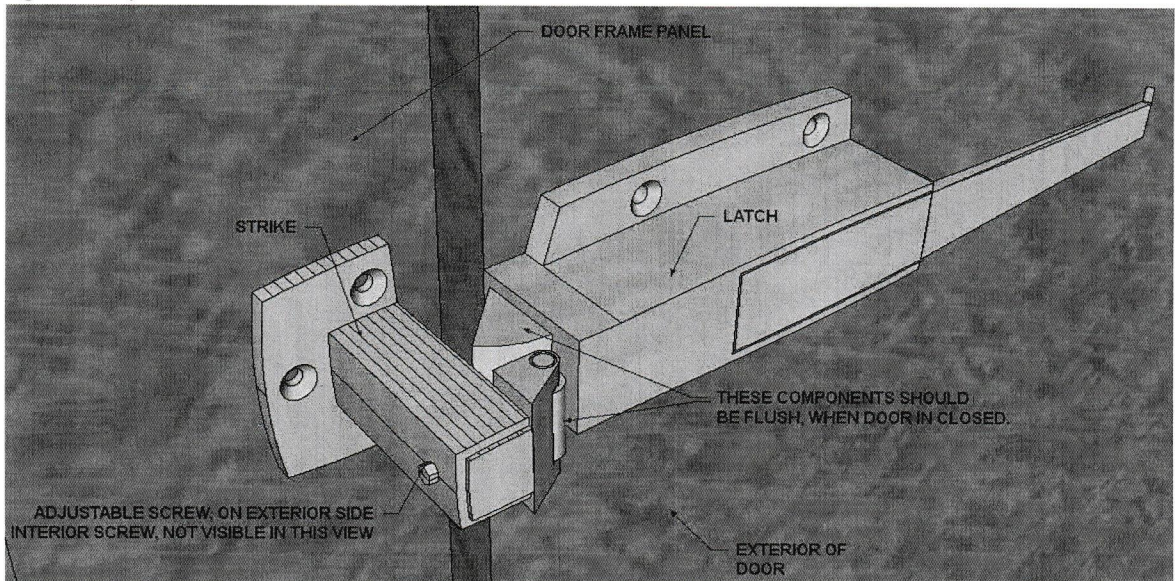

Figure 19.1

Figure 19.2

In some applications the door strike will need to be adjusted as well, to ensure the door closes properly and maintains a tight seal. To accomplish this, use an adjustable wrench and a 7/16" socket wrench to loosen the screws on the interior and exterior side of the strike. Adjust it as needed so that when the door is shut, the latch and strike create a tight seal to the door gasket (Figure 20).

Figure 20



14. Finishing Work

a. Cam Lock Hole Plugs

Install plugs in every cam lock access hole. Simply insert plug with thumb, and gently tap them into place.

b. Final Sealant Instructions

It is extremely important that the cooler/freezer be properly sealed. The installer should use an NSF approved silicone sealant anywhere there could be air flow. They should also run a bead of sealant where the top panels and the wall panels come together on the interior side for coolers or freezers. For coolers and freezers with floors, a bead of sealant needs to be applied on the interior side of the box between the wall and floor, before the floor trim is installed.

c. Sealant Instructions for OUTDOOR coolers and freezers

The following parts of a cooler and freezer need to be sealed in an outdoor application:

- The exterior wall joints
- The exterior junction between the top of the screed and the walls
- The exterior junction between the top of the floor trim and the walls

Please refer to the previous drawings for more detail if needed.

NOTE: Any holes made in the cooler/freezer for electrical/refrigeration purposes will need to be sealed off accordingly as well.

d. Wiring Information

The following gives information related to our heated components for freezer applications:

- Heated Vents= 120 Volt/23 Watts
- Heater Cable (Located around perimeter of freezer door) = 115 Volt/6.5-7.5 Watts per ft.
- Interior Heated Ramp (Located in bottom 10" of ramp) = 115 Volt/6.5-7.5 Watts per ft.

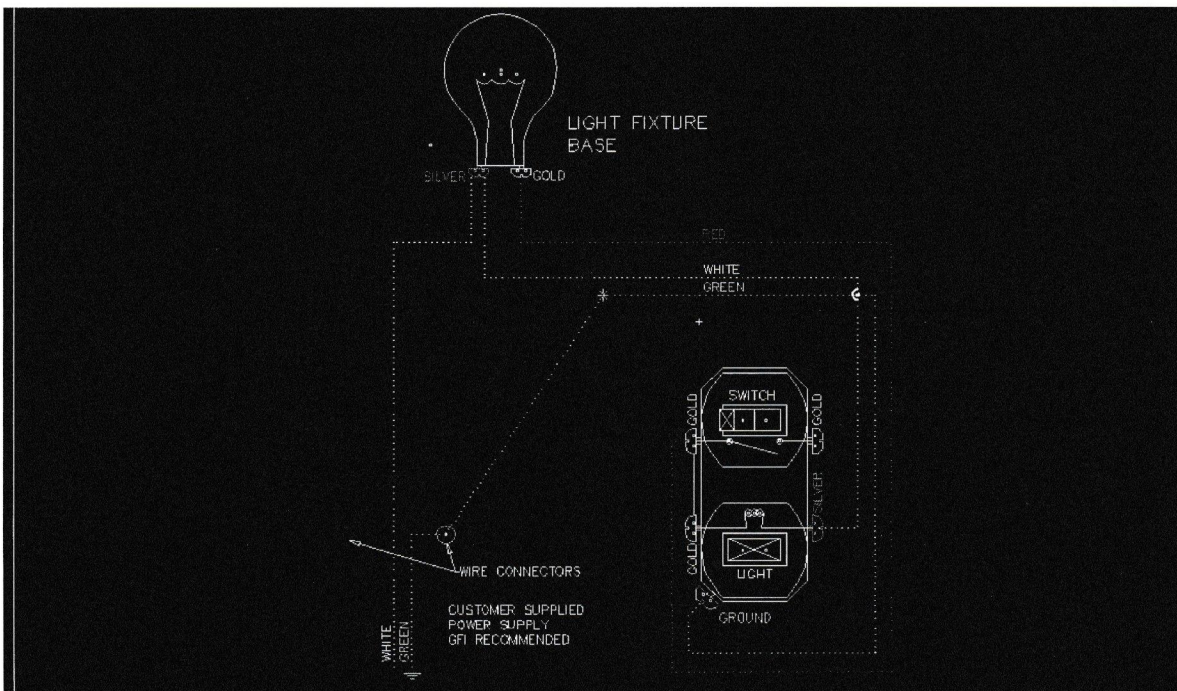

Figure 21.
Cooler Wiring
Diagram

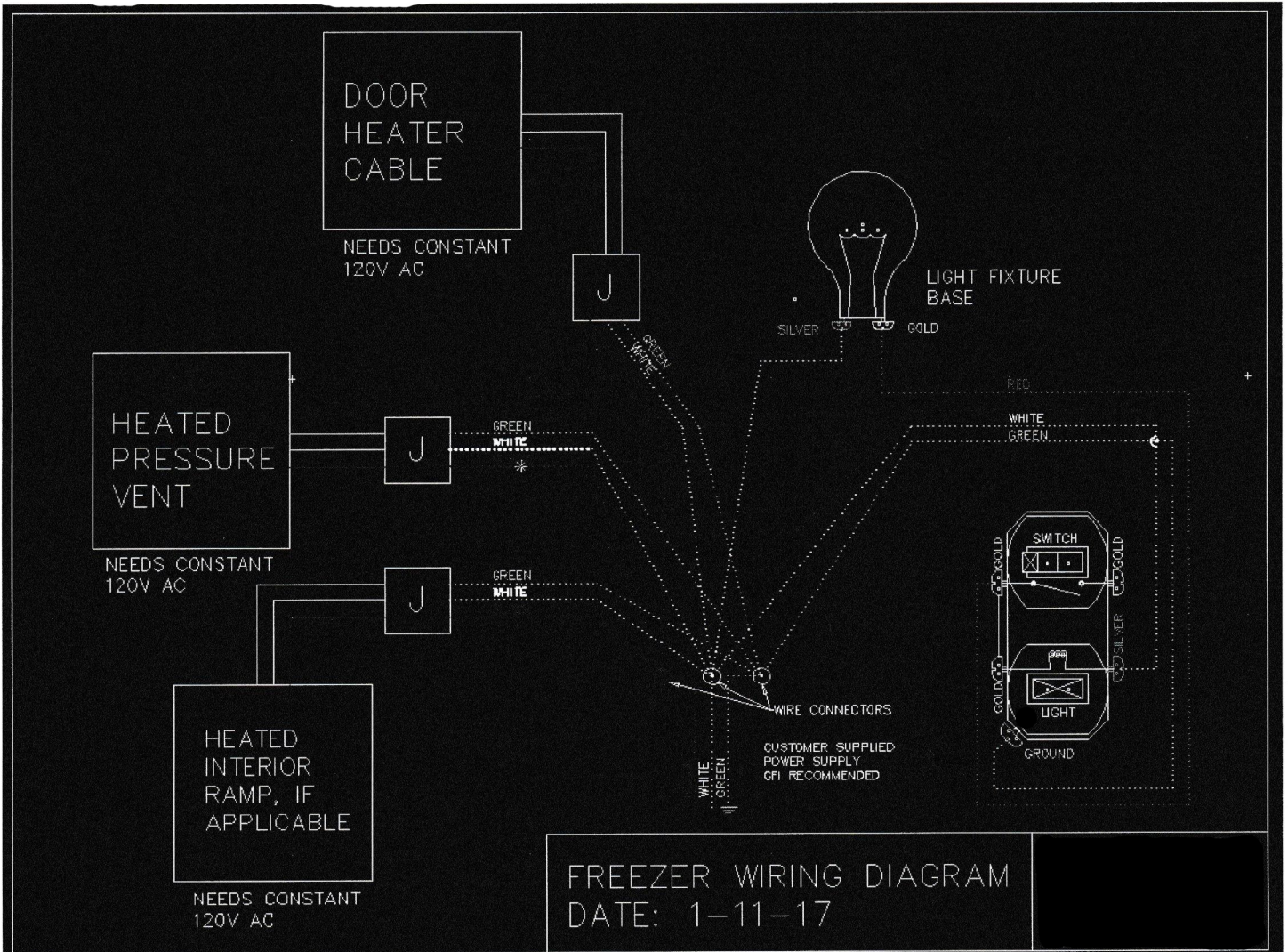

Figure 22. Freezer Wiring Diagram

15. Maintenance

- Wipe up spills immediately with warm water and mild soap. **Do not** use harsh detergents or abrasive cleaners. Dry thoroughly to prevent possible freezing.
- To clean fingerprints or dirt from the wall surfaces, use the same procedure as above
- Check and lubricate door hinges with petroleum jelly as needed.
- Periodically check any door hardware, if anything should become loose or malfunction, contact Mortuary Lift Company Inc. for information, or replacement if necessary.
- Do not store items on the top of the walk-in cooler or freezer. Any resulting damages caused by storing items on top of the box are not covered in by the warranty.