

Operator Manual

The
Stepper[®]

MORTUARY LIFT™ COMPANY 319-364-4910



Contents

1	Introduction and Features -----	4
1.1	General safety instructions -----	5
1.2	Technical data of The Stepper® standard model -----	6
1.3	Technical data of the snap-on battery -----	6
2	Controls -----	7
2.1	Diagram Front -----	7
2.2	Diagram Back -----	8
2.3	The swivel joint -----	9
2.4	Control box -----	10
2.4.1	Button (P) for ascending/descending -----	10
2.4.2	Indicator light -----	10
2.4.3	Speed switch -----	11
2.5	Ascend button in upper handle -----	11
2.6	Safety flap -----	12
2.7	Main switch -----	12
2.8	Switching off -----	12
3	Fitting and Removing the Battery -----	13
3.1	Fitting the battery -----	13
3.2	Removing the battery -----	13
4	Operation-----	14
4.1	Ascending stairs -----	14
4.2	Descending stairs -----	15
4.3	Please pay attention to -----	17
4.3.1	Shift of balance -----	17
4.3.2	Hooking in underneath the step -----	17
4.3.3	Overload -----	18
4.3.4	The Stepper is not a rubber pad -----	18
4.3.5	Inadvertent battery ejection -----	19
4.3.6	Failure to negotiate steps “square-on” -----	19
4.3.7	Driving on a winding staircase -----	20

- 5 Charging the Battery ----- 21
 - 5.1 Battery charger ----- 22
 - 5.1.1 Testing ----- 22
 - 5.1.2 Charging ----- 23
 - 5.1.3 Protective features, technical data ----- 24
 - 5.1.4 Safety rules ----- 25

- 6 Accessories and Liability ----- 27
 - 6.1 QuickStand----- 27
 - 6.2 Pouch (Body Bag) ----- 30
 - 6.3 Straps----- 32

- 7 Warranty and Liability ----- 33
 - 7.1 Warranty ----- 33
 - 7.2 Liability ----- 33

- 8 CE Declaration of Conformity ----- 34

- 9 Design Protection by Patents ----- 34

1. Introduction and Features

Congratulations!

With The Stepper® you have purchased a handy modular-designed hand truck with an unladen weight of only 55 lbs.

Once you fit the snap-on battery, this simple hand truck becomes a versatile all-a-rounder: a normal hand truck for general use on level ground and a powered stair climber for use on steps and stairs.

With The Stepper® climbing stairs has been reduced to the essential: The Stepper® pulls itself up onto the step above and lifts only to the necessary step height.

During descent the motor acts like an electric brake and the load is brought down without “bumping”. It is also ideal for winding staircases and across tight landings.

The Stepper® has a mechanical clutch, which will prevent damage if the unit is used to descend the stairs with the controls in the ascent position.

The unit also features electronic overload protection preventing ascent with too heavy of a load.

The Stepper® has two ascending speed settings (slow and fast – with a speed of up to 48 stairs per minute), plus additional accessories.

In other words, an extra set of hands for the professionals!

1.1 General safety instructions

In order to ensure that this product is used safely, be sure that you read and understand the following precautions fully and use the product only as directed. Be sure to read these Safety Instructions carefully before installing, connecting, operating, maintaining, or inspecting this product. Follow all the precautions and directions given here.

- Always ensure that there is no one beneath the load
- Always secure the load with the appropriate straps/body bag
- Always wear skid-proof shoes – some stairs can be extremely slippery
- Always wear shoes with steel caps
- Never reach into the lifting mechanism with your hands if the battery is inserted
- At first practice using The Stepper® either unladen or with a light load of 40-60 lbs.
- For all transportation remove battery to lighten the unit and to prevent accidental operation in transit.

1.2 Technical data of The Stepper®

Model ERGO/UNI/FOLD	
Capacity	375 lbs.
Maximum climbing speed	29 steps/min
Weight	55 lbs.
Maximum step height	8.5"

1.3 Technical data of the snap on battery

Fuse:	Internal blow-out fuse (30 amps)
Plug-socket for charger:	DC jack ø 2.1 x 9.5
Weight:	9 lbs.
Capacity:	5 Ah
Voltage:	24 VDC (2 x 12 VDC – 5 Ah)
Battery cells:	Sealed lead acid maintenance-free and approved for air travel by DOT and IATA

2. Controls
2.1 Diagram – Front

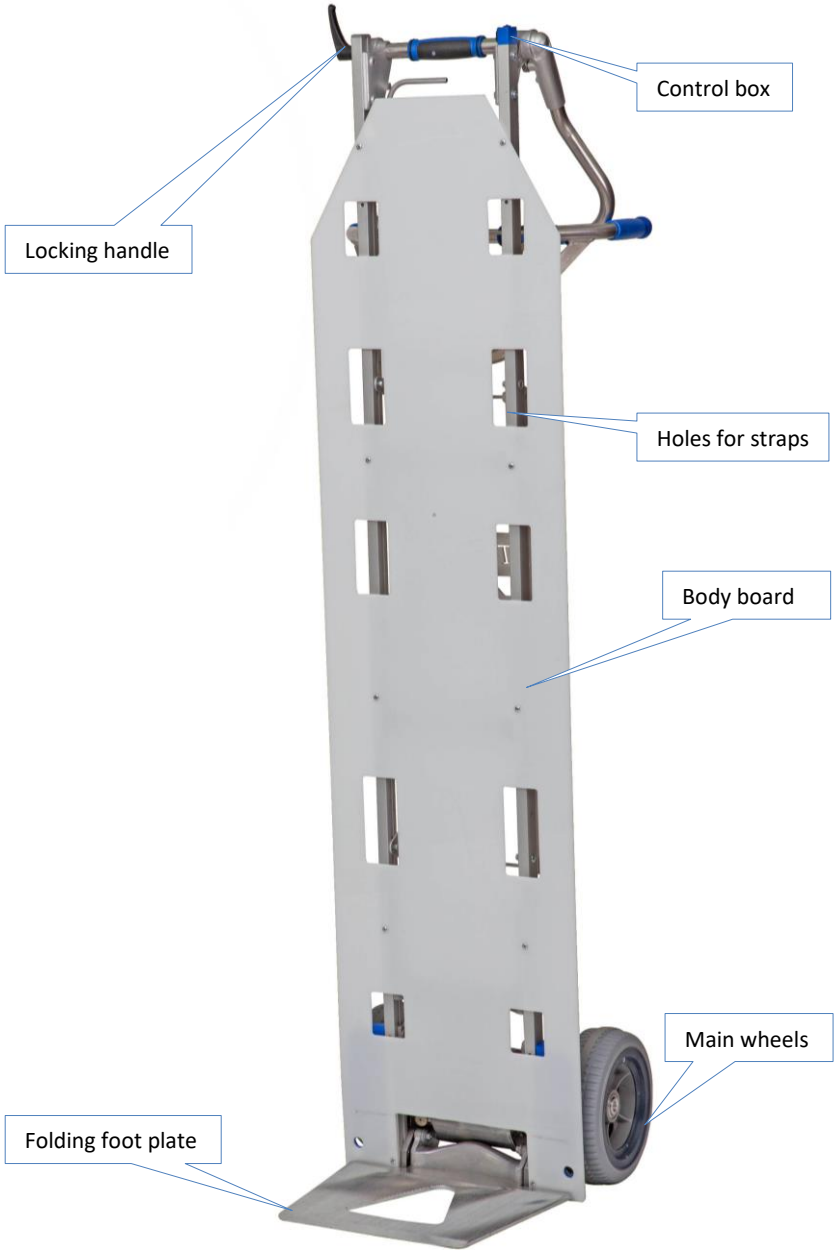

2.2 Diagram – Back

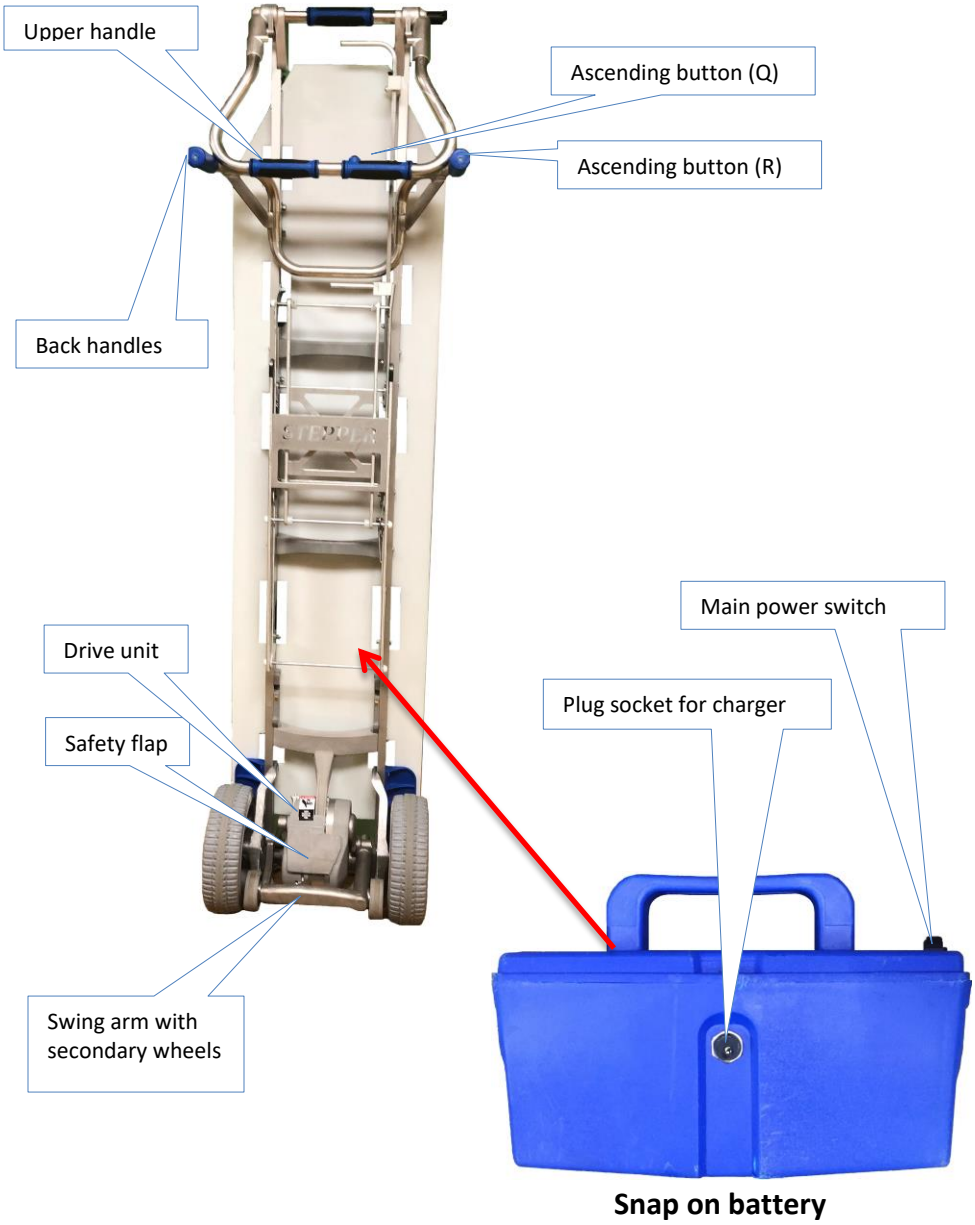

2.3 The Swivel Joint



The necessary friction for the rotary joint is obtained through multiple friction disks, which are compressed simultaneously on the left and right sides. The lock must be tightened sufficiently to avoid movement in use.

As a rule: The lock will be sufficiently tightened if a single operator can tilt back the load from the upright position without any handle movement.

Safety instruction: With heavy loads (over 200 lbs.) ensure the lock is tightened especially firmly.

2.4 Control Box

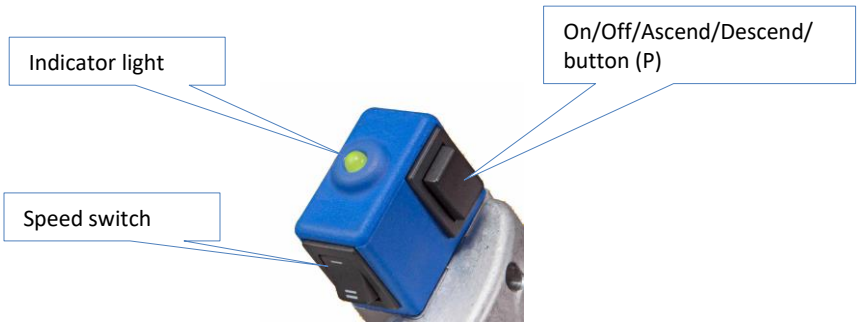

2.4.1 Button (P) for ascending/descending

- Briefly press the push button to switch The Stepper® to ascent mode or descent mode. See section 4.1 **Operation**.
- If the button is pressed for more than 3 seconds,
The Stepper® will switch off.

2.4.2 Indicator light

- Shines green: The Stepper® is in ascent mode. (In the ascent mode the push button Q or R in the upper or lower handlebar is active. The lifting mechanism operates when the push buttons Q or R is pressed and stops when released (refer also to chapter **Operation** [4.1])
- Flashing green: The Stepper® is in descent mode. (The push buttons Q and R are not active now – refer also to chapter **Operation** [4.2])

- Constantly red: The Stepper® is in descent mode and the support wheels move (fast) to the descend position (takes a max. of 0.5 seconds – refer also to chapter **Operation** [4.2])
- Flashing red: The Stepper® is overloaded. (Flashes for 3 seconds and goes out – see also chapter **Operation** [4.3.3])

2.4.3 Speed Switch

Use the speed switch to select either high or low speed – this can only be used in ascent mode. (In descent mode the descending speed is permanently set so that optimum braking will always be secured – refer also chapter **Operation** [4.2])

Low speed is advised for: training, heavy loads and in awkward locations.

2.5 Ascend button in upper and lower handles

This button [Q] and [R] is only active in the ascent mode and switches the lifting mechanism on and off.

2.6 Safety flap

To start tilting the load, it may be necessary to use your foot to assist in tilting. The axle of the conventional hand truck is normally used for this purpose. With The Stepper[®], the swing arm with the support wheels, a wheel, or the drive unit may be used to support by foot. The safety flap is installed to prevent your foot getting jammed in by the swing arm. If you press onto the lower part of the flap with your foot all functions will be stopped.

Safety instructions: You avoid all risk if you switch on only after tilting the load.

2.7 Main switch

The main switch is situated on the battery cover. The power supply is switched on or off by way of the main switch.

2.8 Switching off

Battery power is removed:

- By switching off the main switch on the battery unit
- By removing the battery
- By pressing button (P) for 3 seconds
- Automatically after 10 minutes

NOTE: The main switch or removal of the battery provides a higher degree of safety than switching off with the button P or with the timer cut-out, as button P may be touched inadvertently.

3. Fitting and removing the battery

3.1 Fitting the battery

- (1) Locate corner "A" on both sides and hook into "B" on frame
- (2) Snap battery forward to engages locking hooks

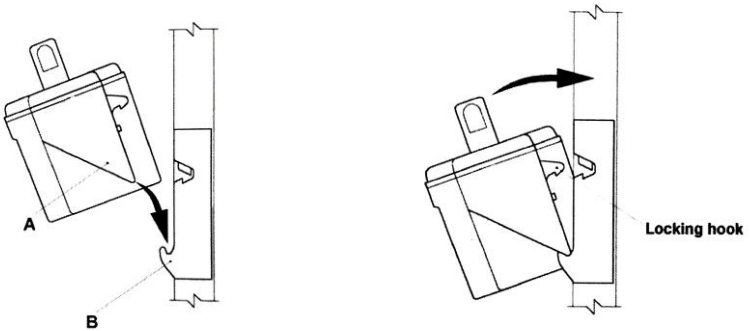

3.2 Removing the battery

Battery must be lifted vertically to disengage locking hook.
Do not hinge back.

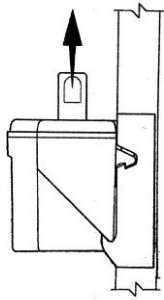

4. Operation

4.1 Ascending stairs

Press button (P) briefly until the indicator light shines green continuously.

The Stepper® is now in the UP MODE.

Pressing the button (Q) or (R) in the upper handle or lower handle, will operate the support wheels and will lift The Stepper® over the step continuing until the button is released.

Important:

On each cycle, immediately the main wheels rest on the tread, roll The Stepper® back to touch the rise of the next step up.

Note: Holding The Stepper® too flat, on stairs with open risers, can also result in the support wheels being partially trapped under the tread. This may result in excessive pressure on the drive unit, causing it to go into overload mode, and shutting down. Press button (P) to reset.

4.2 Descending stairs

Press button (P) briefly again until the indicator light flashes green. The Stepper® is now in the DOWN-MODE and the support wheels will move to the descend position automatically.

The ascending buttons Q & R are now out of function.

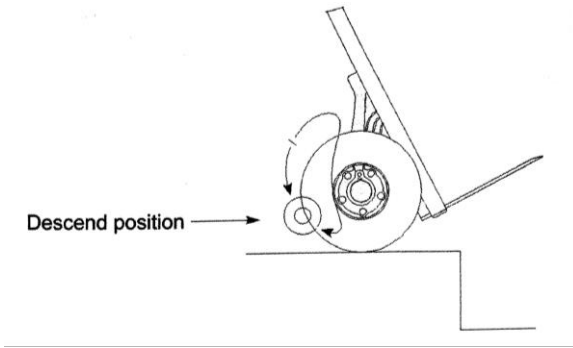

With the support wheels in the descend position The Stepper® can be rolled over the step margin and the support wheels will, under controlled conditions, lower the machine onto the next step down. When the main wheels land on the lower step, the support wheels automatically rotate to the descend position for the descent onto the next step down, all within approximately half a second.

During the descent movement the indicator light changes to constant red. After reaching the descend position the light changes back to flashing green.

Important:

As soon as The Stepper® rolls off the tread, ensure the main wheels are kept against the rise until the support wheels reach the descend position.

Note: Just before the suspension arm reaches the descending position, the support wheels reach the upper edge of the stair and lift The Stepper® approximately a ½ inch. This is normal and is used as an advance signal by experienced drivers. As a matter of fact, you may already advance while the support wheels are in contact with the floor. This results in smooth continuous down-the-stairs motion.

Note: In the case of closed stairs with short step, for instance on the inside of a narrow circular staircases, the support wheels may touch the stair step and The Stepper® can move approximately 3 to 3 ½ inches forward. This also is normal since The Stepper® will then be ready for advancing again anyway.

Note: If the load is under 35 lbs. or the driver holds back the load, the automatic movement to the descend position will be slowed down.

Unlike all other stair climbers, the operator does not need to control the electrics to descend, as the support wheels operate automatically.

4.3 Please pay attention to

4.3.1 Shift of balance

When ascending the balance of the load changes as soon as the support wheels start lifting the load. Operators quickly become accustomed to this and compensate by tilting the handle.

Initially, before this operation becomes automatic, care should be taken at the point where the support wheels take the load when ascending. There is a forward movement of the machine, which is easily compensated for by tilting the handle backwards.

Lowering backwards by 10° to 20° before the support wheels start to lift eliminates any major forward movement.

4.3.2 Hooking in underneath the step

Under normal operating conditions, with the load in a well-balanced position, the moving support arm is always clear of the underside of the upper step. If The Stepper[®] is laid back too far, the support arm will be tripped by touching the tread it is on, causing it to rotate under the upper tread. The electronics will go into overload mode and will need to be reset.

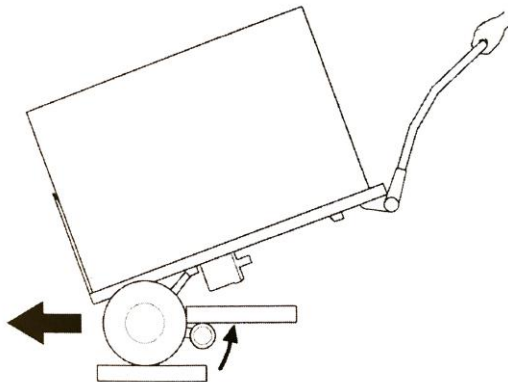

4.3.3 Overload

DO NOT OVERLOAD

Exceeding the load capacity will activate overload mode causing the operation to stop, lowering the main wheels slowly to the lower step. The indicator lamp flashes red for about 3 seconds after which the ascend/descend button will need to be reset.

Note: Once the battery has been discharged the unit will go into overload even with loads below the specified capacity.

4.3.4 The Stepper® is not a rubber pad

DO NOT use The Stepper® as a pad for dropping heavy objects upon.

This is not possible with The Stepper® when the support wheels are in the descending position.

The impact will be transmitted to the connecting bar via the drive unit, which may result in fracture. With the support wheels raised between the main wheels, throwing heavy objects on the unit is possible in principle since the pneumatic tires would absorb part of the impact, it is nevertheless not recommended as it is detrimental to the life of The Stepper®.

4.3.5 Inadvertent battery ejection

For all normal operations the battery is held securely by locking hooks.

A strong pull is required to remove it. Abuse of The Stepper® by moving backwards very quickly, and striking a high step, or similar, will result in the batter being ejected from its location.

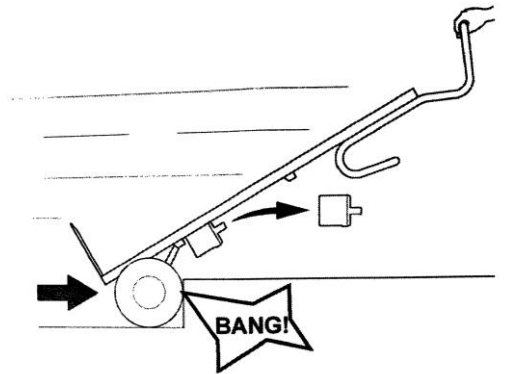

4.3.6 Failure to negotiate steps “square-on”

Failure to negotiate steps “square-on” will result in damage to the underside of the drive unit.

4.3.7 Driving on a winding staircase

When you must drive on a winding staircase please pay attention to the following:

When ascending, The Stepper® tends to move to the inside of the staircase (any step a few inches depending on the angle of the winding). Therefore, start as far as possible to the outside when ascending.

When descending, The Stepper® tends to move to the outside of the staircase. Therefore start as far as possible at the inside when descending. However, if the winding staircase is still too narrow it is possible to move sideways by reversing - preferably at one of the wider steps.

5. Charging the battery

The battery-cells within the battery housing are maintenance-free, sealed and rechargeable. Their durability largely depends on the charge/discharge cycles. It is possible for instance to extract far more than 1000 partial discharges from lead-acid batteries if total discharge is avoided.

- For this reason, avoid total discharge. Recharge as often as possible
- Lead-acid batteries are subjected to 'self-discharge'. For this reason, the snap-on battery should be recharged after a maximum of three weeks of disuse.
- The charger automatically switches to trickle charging so overcharging is not possible.
- Do not leave the battery discharged or half discharged. Always charge immediately after use.
- The optimum temperature for charging is 68-77° F. Too cold or too warm has a negative effect on the capacity.

Note: If the battery has not been fully charged or tends to lose charge too rapidly, this will not only reduce the speed of The Stepper® but also reduce the capacity. It may move into the overload mode as a result, even with light loads. See **Operation** [4.3.3]

5.1 Battery charger

High performance is achieved by 2-step automatic and digital control engineering. This allows for quick charging in the first step, then compensation/trickle charging in the second step. It is possible to check the condition of the battery. With LCD display and revolving mains plug.

5.1.1 Testing

Connect the battery charger with the battery (without plugging into the mains).

After approximately 9 seconds the test result is displayed (off-load voltage of the battery)

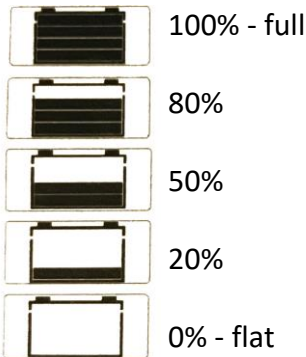

5.1.2 Charging

- (1) Connect the charging unit to the battery
- (2) The off-load voltage of the battery is shown on the display
- (3) Plug the charging unit into the mains
- (4) The charging operation begins

The present charge status of the battery is symbolized by progress bars:

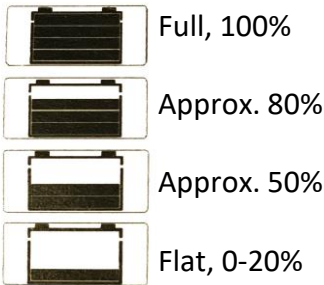

Compensation/Trickle charging

Once the battery is fully charged, the charging unit switches over to compensation/trickle charge. On the display, the battery symbol is shown with 4 bars and remains solid. (insert picture here)

If charging does not begin, there are two possible reasons:

Display: + and - and the charge symbols blink alternately indicating **polarity reversal**

Display: Battery and the charge symbols blink alternately indicating a **break in connection** to battery, contact-fault check charging clips, cables, contacts, battery-pole terminals, etc.

5.1.3 Protective features, technical data

Protective features

- Protection if the charging clips are short-circuited
An electronic protection circuit prevents damage if the charging clips are short-circuited.
Display: The first bar blinks
- Protection from charging-cable polarity reversal
An electronic protection circuit prevents damage if the charging cables are connected with reverse polarity.
Display: The + and - and the charge symbols blink alternately
- Protection against the charger overheating
If the room temperature increases, the charger will reduce the charging current and interrupt the charging operation if necessary. As soon as the unit cools, charging resumes.

Safety cut-out

If the battery fails to reach a certain voltage value within a pre-determined time, the charger automatically cuts out.

What to do after a safety cut-out:

1. Unplug the charger from the mains
2. Disconnect the charger from the battery
3. Investigate the reason for the safety cut-out

Technical data

Mains voltage (50/60 Hz, +/-15 %)	100-230 V AC
Open-circuit power consumption	max. 1.5 W
Rated power output	48 W
Charging voltage	24 V DC
Arithmetic charging current with 230 V/ 50 Hz	2.0 A
Degree of protection	IP30
Time until safety cut-out	4.5 h

The charger has been function tested

- in a temperature range from -4° F to 122° F
- in atmospheric humidity ranging from 5-85%

Component specification: Climatic category B

5.1.4 Safety Rules

Utilization for intended purpose only

- This battery charger is designed to charge **lead storage batteries filled with liquid, gel and AGM (absorbed glass mat) electrolytes** only.
- This battery charger should never be used to charge NiCd and NiMH batteries and primary cells.

Only use the unit if

- It is protected from direct sunlight and kept dry, and
- Cooling air can flow through the ventilation slots unhindered

CE marking

This battery charger meets the fundamental requirements of the Low-Voltage and Electromagnetic Compatibility Directive and is thus CE-marked

6. Accessories
6.1 QuickStand™

NEVER LEAVE LOAD UNATTENDED

QuickStand™ IS NOT DESIGNED FOR LATERAL MOVEMENT

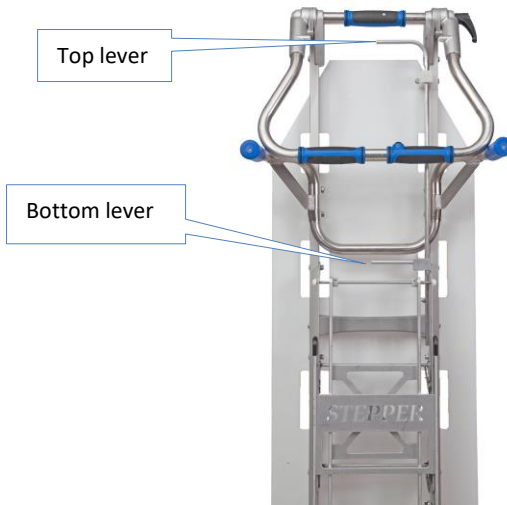

Fig. A

Stage 1

1. Pull and release top lever (Fig. A, B)
2. Apply firm grip to top handle (Fig. B)
3. Use legs to stand and raise The Stepper® continue raising The Stepper® until the QuickStand™ clicks into stage 1 (Fig. C) position



Fig. B



Fig. C

Stage 2

1. Adjust hand grip on top handle to a bicep curl position
2. Once load is secure, pull and release top lever
3. QuickStand™ will now be able to extend or collapse
4. Continue lifting until QuickStand™ locks into stage 2 (Fig. D) position



Fig. D

Stage 3

1. Adjust hand grip to back handles (Fig. D)
2. Push The Stepper® to a vertical position (Fig. E)
3. While securing and steadying the load, pull the bottom lever (Fig. A) then slide the QuickStand™ into collapsed position (Fig. F).



Fig. E



Fig. F

6.2 Pouch (Body bag)

Attaching the pouch:

(May use own pouch or one purchased from Mortuary Lift Company™)

- Fasten the pouch to the top bar of The Stepper
- (figure A)
- Fasten the pouch through the holes in the white body board, near the bottom of The Stepper (figure B)
- Make sure pouch is secure so it does not slip or slide off the white body board



Fig. A



Fig. B

Body bag (pouch) holes:

- Locate the holes on the backside of the pouch.
- Straps may be slipped into and through the pouch or fastened over the outside of the pouch to secure remains.
- When transferring remains from The Stepper® to a removal stretcher, grab side straps that are located down the entire length of each side of the pouch.

Note:

-The pouch may be hosed out and/or bleached – pouch is bleach-safe.

-Washing in a washing machine will limit the longevity of the pouch.

-Never put the pouch in a dryer.

6.3 Straps

- From the front of The Stepper, insert the loop end of the strap through the hole in the white body board.
- Then strap then loops around The Stepper frame and through the same hole in the white body board again.
- Insert the metal end of the strap through the loop
- Pull on the strap to tighten around the frame
- Make sure to use a male end on one side of the frame and a female end on the exact opposite side of the frame.



Step 1



Step 2



Step 3

7. Warranty and liability

7.1 Warranty

The warranty period for The Stepper® is 12 months (6 months for batteries) from the date of purchase and covers defective material and production faults.

Not included in the warranty are:

- Normal wear and tear on parts
- Damage resulting from abnormal load
- Damage due to the exertion of force
- Inadmissible modifications to the unit or accessory parts

7.2 Liability

Mortuary Lift Company™ is not responsible for the safety of The Stepper® if:

- The Stepper® is used other than is intended
- The Stepper® is not regularly (once a year) maintained by an authorized workshop
- The instructions of these Operating Instructions are not observed
- Non-original parts are installed or connected with The Stepper®
- Original parts are removed

Restocking Fee

If the original retail purchaser is not satisfied with the product, MLC will refund to such purchaser the full purchase price, subject to a \$2000.00 restocking fee, provided the purchaser returns the product in all the original packaging with all shipping and freight insured by the purchaser, in good condition to MLC within 60 days from the date of shipment. Custom orders are non-refundable.

8 CE declaration of conformity



Mortuary Lift Company™ declares that The Stepper® stair trolley corresponds to the applicable basic safety and health requirements of the CE Guidelines for machines 2006/42/EEC, appendix IIA. This declaration will lose its validity if changes are performed on the unit without our approval.

Katie Hill,

Company
Owner

9 Design protected by patents

The lifting system of The Stepper® is protected by international patent applications for Europe, USA, and Japan. The modular structure of the basic frame is also protected by a patent application as well as the rotary joint of the FOLD model patent is pending.